



Hadronic Interactions

FLUKA Beginner's Course

Hadronic showers: many particle species, wide energy range

100 GeV p on Pb
shower longitudinal development

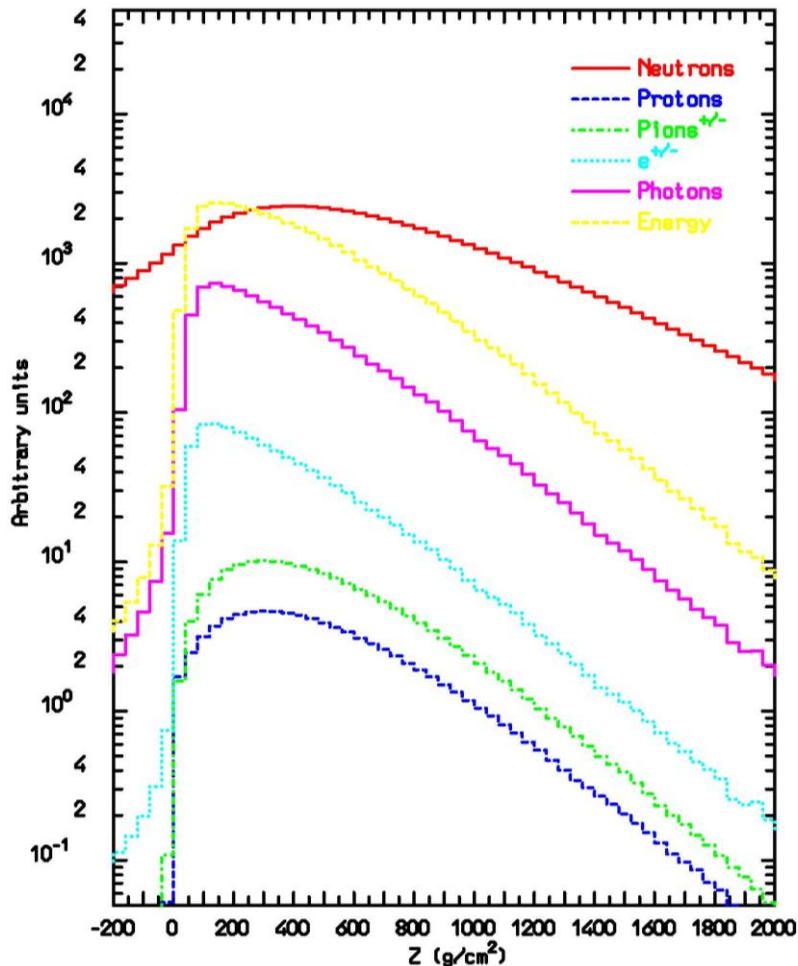

100 GeV p in a Fe absorber:
space-averaged particle spectra

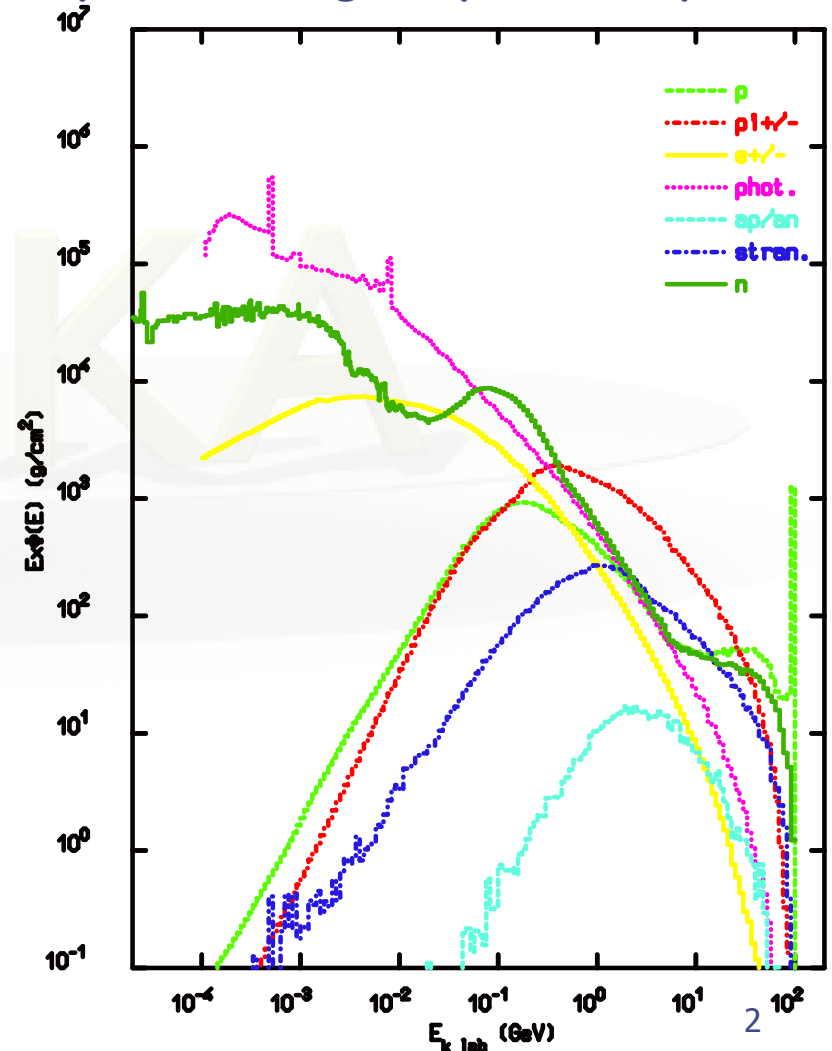

Hadronic showers: we want to simulate also what is left !

Residual nuclei distribution
Following 15 GeV proton
interactions on Lead

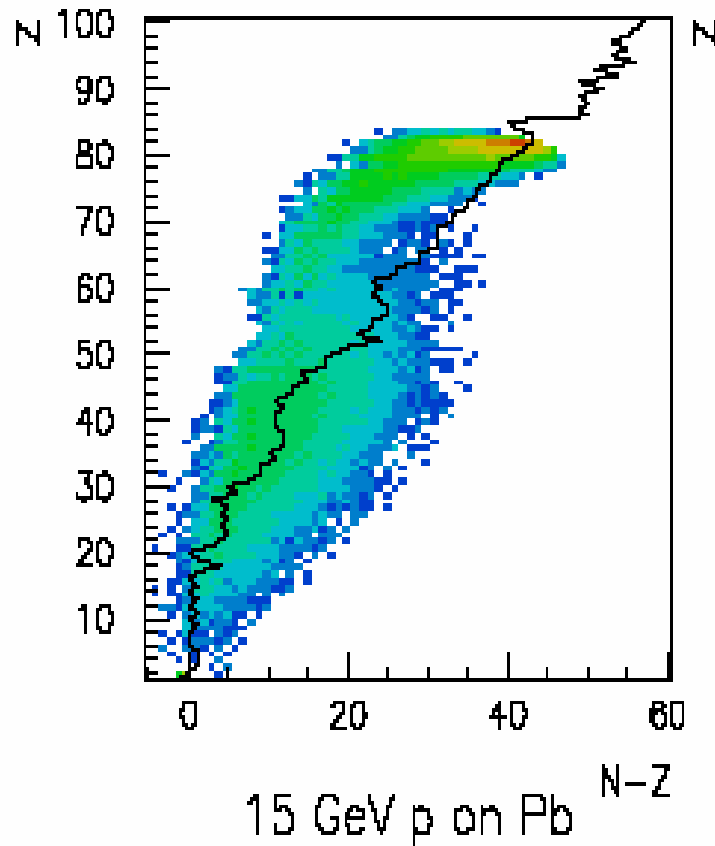

- The MC should be able to reproduce this complexity, maintaining correlations and cross-talks among the shower components
- Hadronic interactions have to be simulated over a wide energy range with an high degree of accuracy
- Nuclear effects are essential
- => need detailed nuclear interaction models
- => need checks on simple data (thin target)
- A summary of the hadronic interaction models used in FLUKA is given in the following

The FLUKA hadronic Models

Hadron-nucleus: PEANUT

Elastic, exchange
Phase shifts
data, eikonal

$P < 3-5 \text{ GeV}/c$
Resonance prod
and decay

Sophisticated
G-Intranuclear Cascade

Gradual onset of
Glauber-Gribov multiple
interactions

Preequilibrium

Coalescence

hadron

hadron

low E
 π, K
Special

High Energy
DPM
hadronization

Evaporation/Fission/Fermi break-up
 γ deexcitation

Hadron-nucleon interaction models

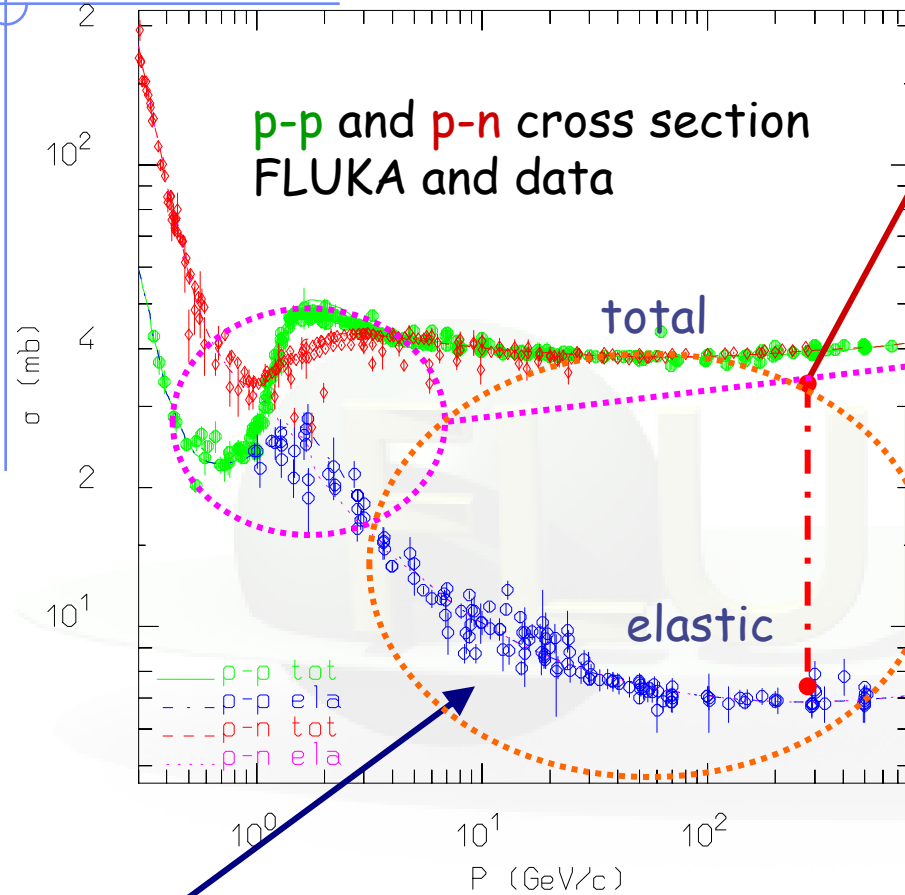

Particle production interactions:
two kinds of models

Those based on "resonance"
production and decays, cover the
energy range up to 3-5 GeV

Those based on quark/parton
string models, which provide
reliable results up to several tens
of TeV

Elastic, charge exchange and strangeness exchange reactions:

- Available phase-shift analysis and/or fits of experimental differential data
- At high energies, standard eikonal approximations are used

Nonelastic hN interactions at intermediate energies

RESONANCE PRODUCTION

All reactions are thought to proceed through channels like:



where X and Y can be real resonances or stable particles (π , n, p, K) directly (the intermediate state contains at least one resonance)

Resonances can be treated as real particles: they can be transported and then transformed into secondaries according to their lifetime and decay branching ratios

Resonance energies, widths, cross sections, branching ratios
from data and conservation laws, whenever possible.
Inferred from inclusive cross sections when needed

Dominance of the Δ resonance and of the N^* resonances

FLUKA: ≈ 60 resonances, and ≈ 100 channels in describing p, n, π , pbar, nbar and K induced reactions up to 3-5 GeV/c

Nonelastic hN interactions at intermediate energies

- $N_1 + N_2 \rightarrow N'_1 + N'_2 + \pi$ threshold at 290 MeV, important above 700 MeV,
 - $\pi + N \rightarrow \pi' + \pi'' + N'$ opens at 170 MeV.
- Anti-nucleon-nucleon open at rest !

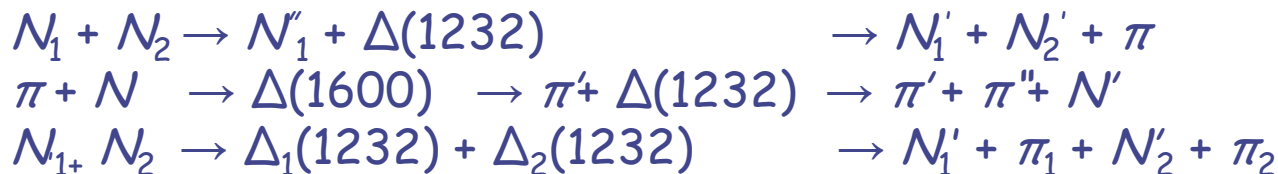
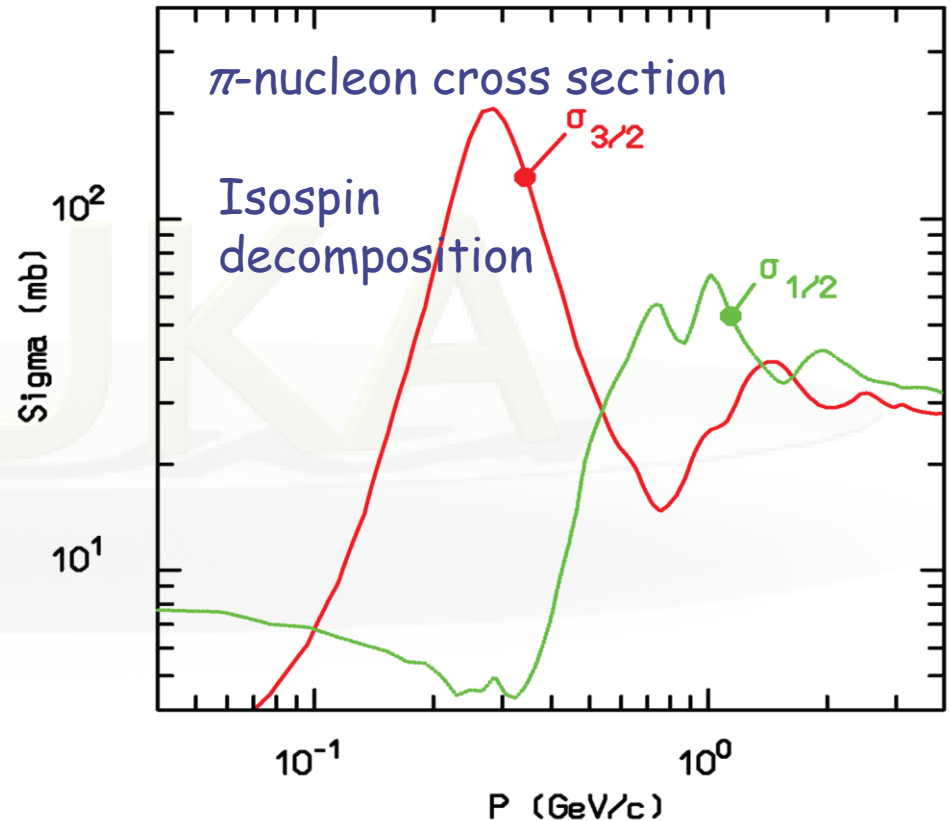

Inelastic hN at high energies: (DPM, QGSM, ...)

- Problem: "soft" interactions → QCD perturbation theory cannot be applied.
- **Interacting strings** (quarks held together by the gluon-gluon interaction into the form of a string)
- Interactions treated in the Reggeon-Pomeron framework
- each of the two hadrons splits into **2 colored partons** → combination into **2 colourless chains** → **2 back-to-back jets**
- each jet is then **hadronized** into physical hadrons

DPM

Parton and color concepts, Topological expansion of QCD, Duality

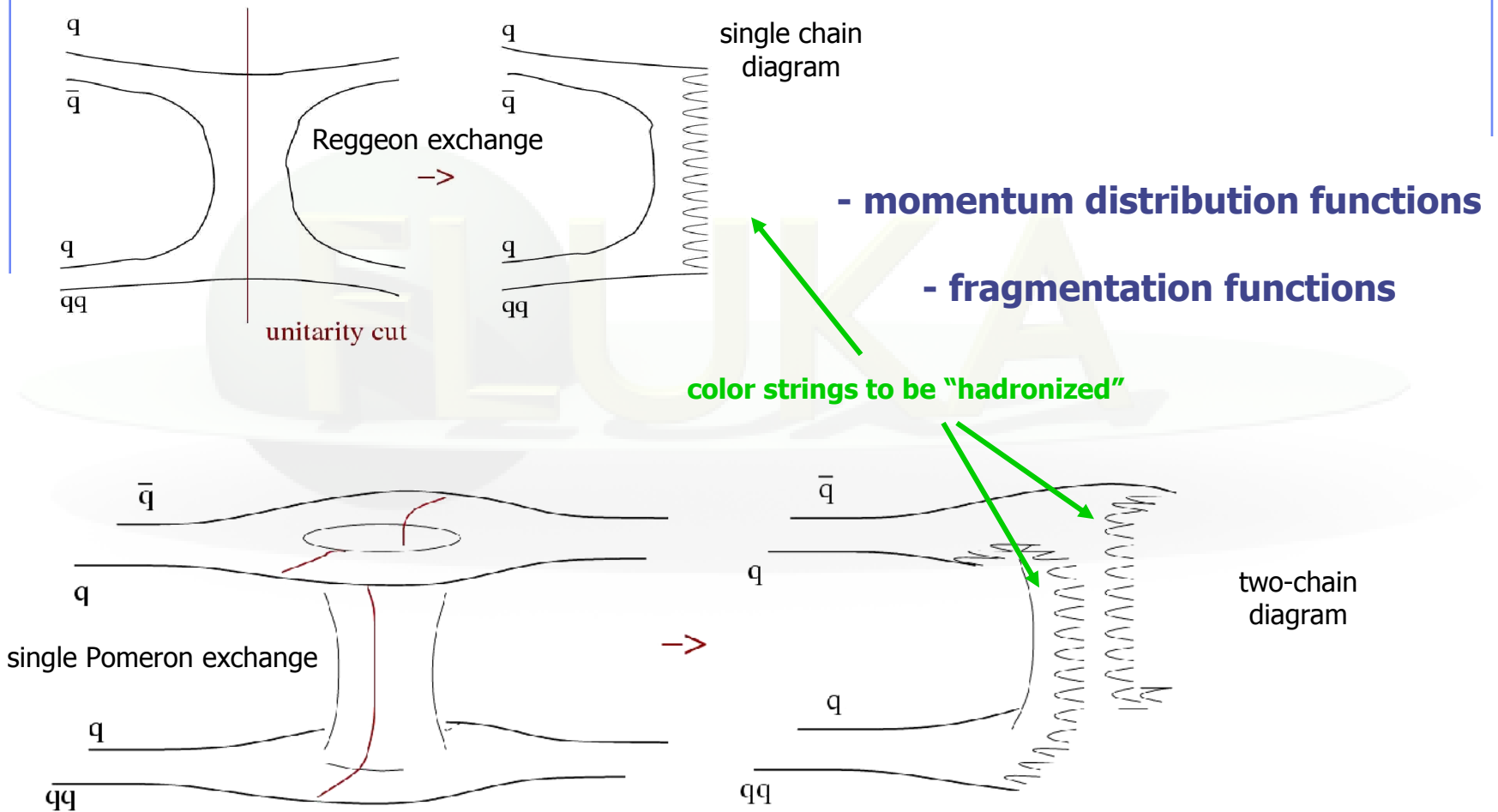

Hadron-hadron collisions: chain examples

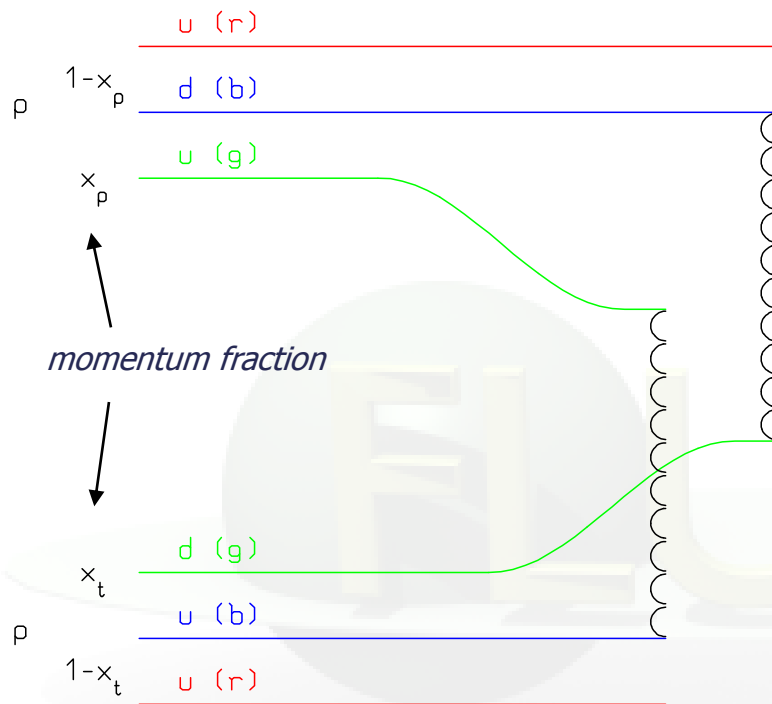

Leading two-chain diagram in DPM for **p-p scattering**

The color (red, blue, and green) and quark combination shown in the figure is just one of the allowed possibilities

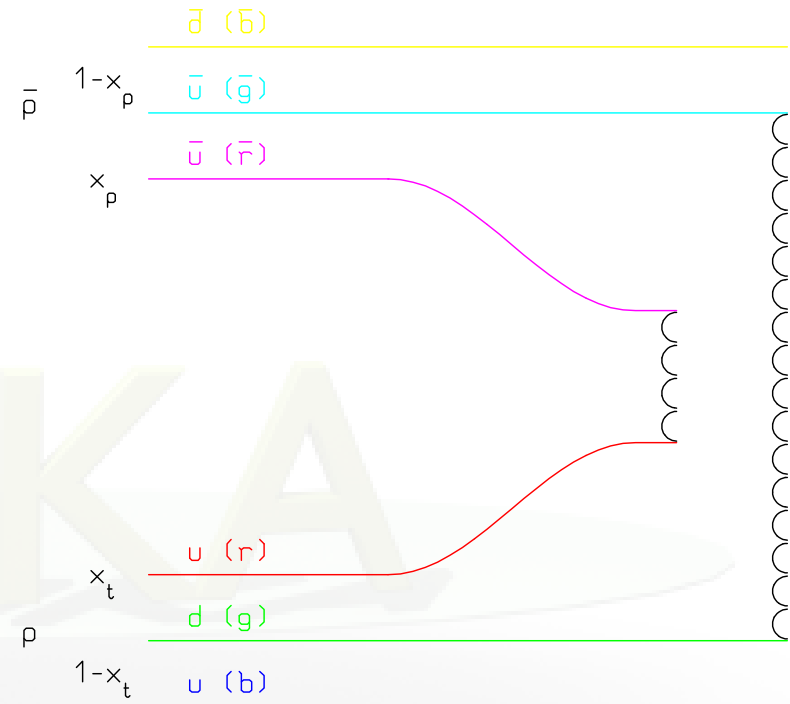

Leading two-chain diagram in DPM for **pbar-p scattering**

The color (red, antired, blue, antiblue, green, and antigreen) and quark combination shown in the figure is just one of the allowed possibilities

Hadron-hadron collisions: chain examples

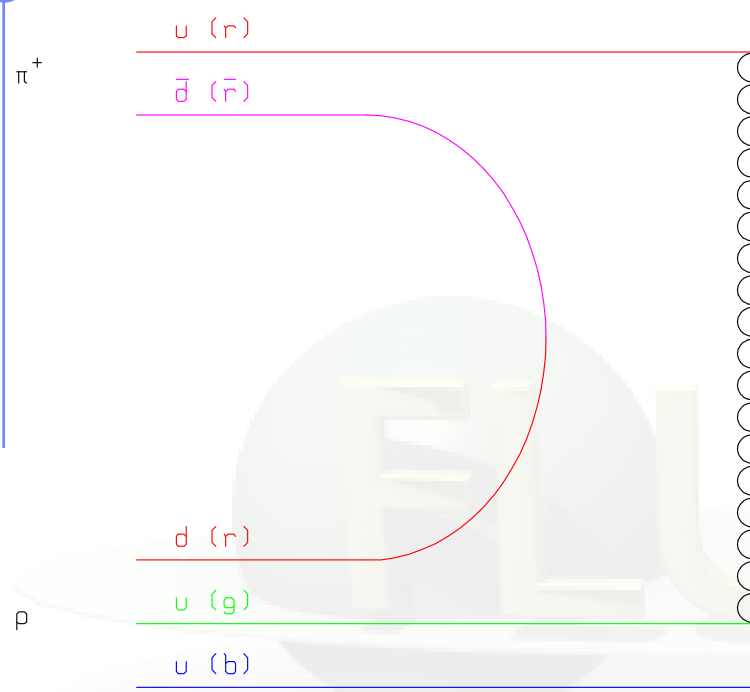

Single chain diagram in DPM $\sigma \sim 1/\sqrt{s}$
for π^+ -**p scattering**

The color (red, antired, blue, and green) and quark combination shown in the figure is just one of the allowed possibilities

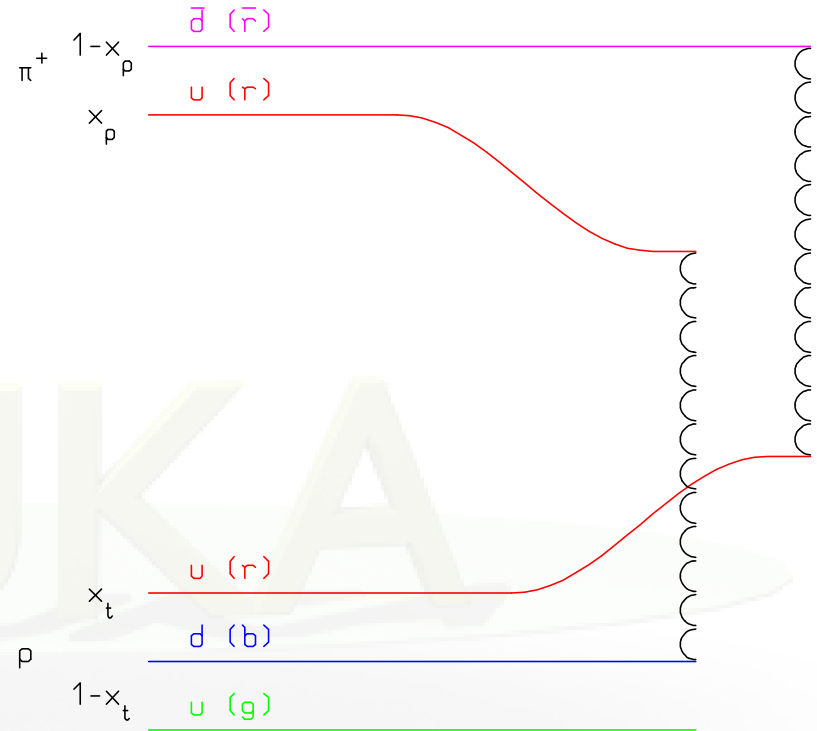

Leading two-chain diagram in DPM
for π^+ -**p scattering**

The color (red, antired, blue, and green) and quark combination shown in the figure is just one of the allowed possibilities

Hadronization example

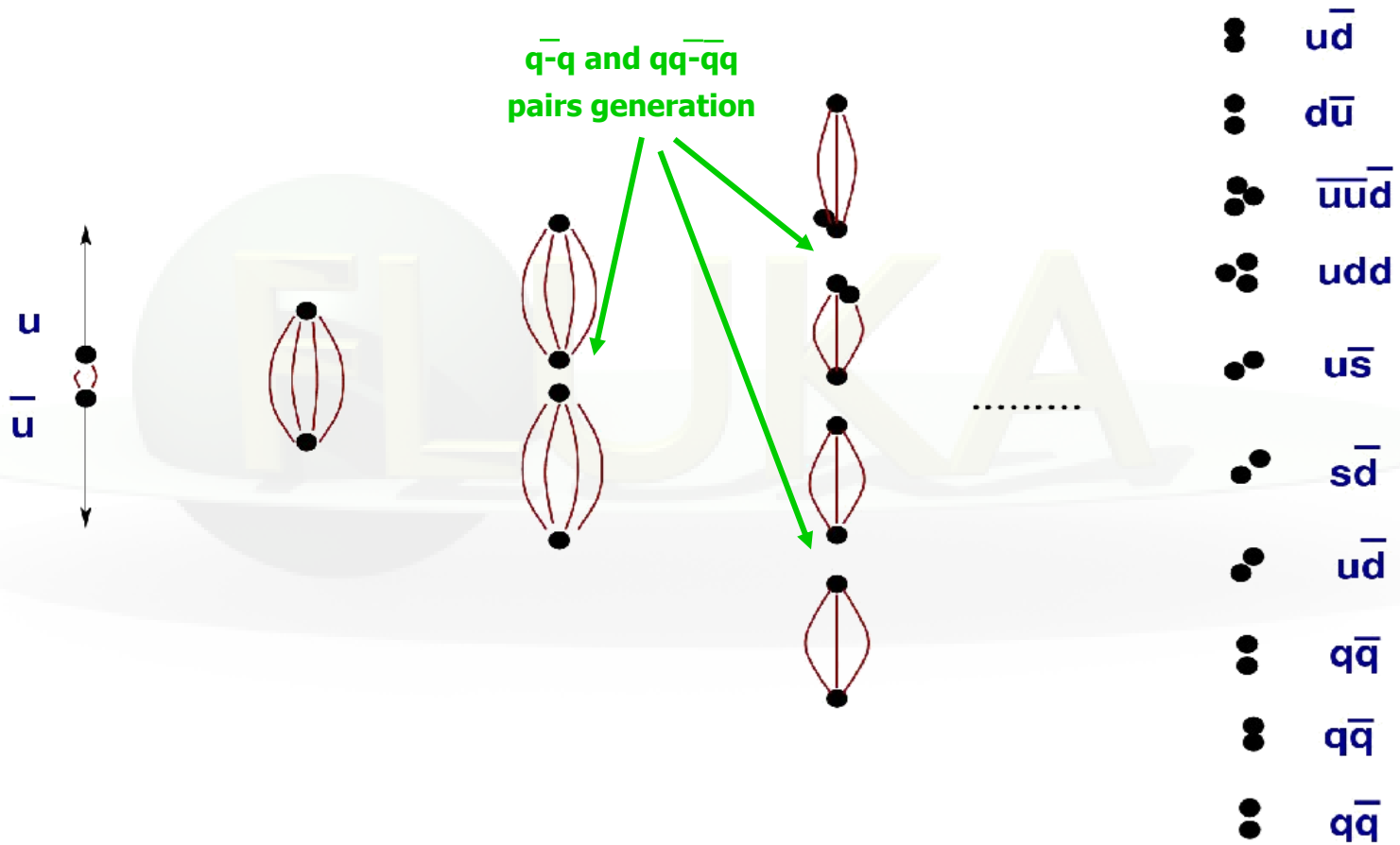

DPM and hadronization

from DPM:

- Number of chains
- Chain composition
- Chain energies and momenta
- Diffractive events

Almost No Freedom

Chain hadronization

- Assumes chain universality
- Fragmentation functions from hard processes and e^+e^- scattering
- Transverse momentum from uncertainty considerations
- Mass effects at low energies

The same functions and (few) parameters for all reactions and energies

Inelastic hN interactions: examples

$\pi^+ + p \rightarrow \pi^+ + X$ (6 & 22 GeV/c) $\pi^+ + p \rightarrow \text{Ch}^+/\text{Ch}^- + X$ (250 GeV/c)

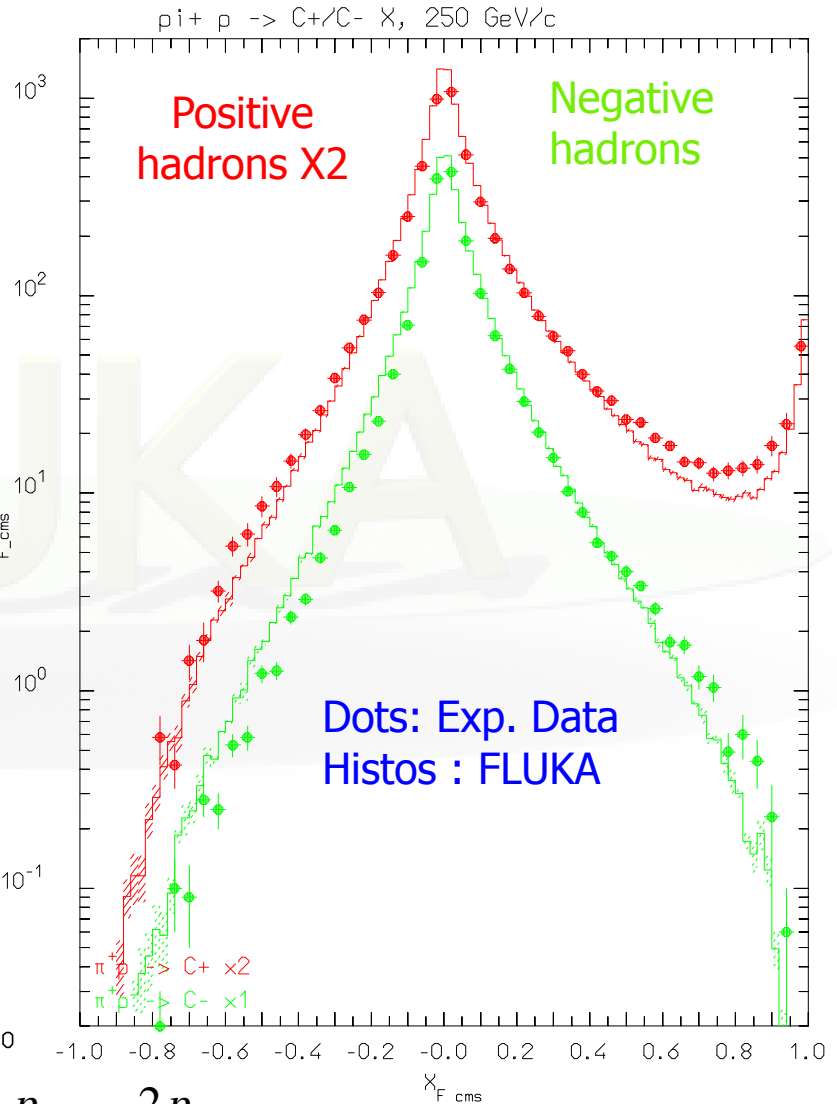
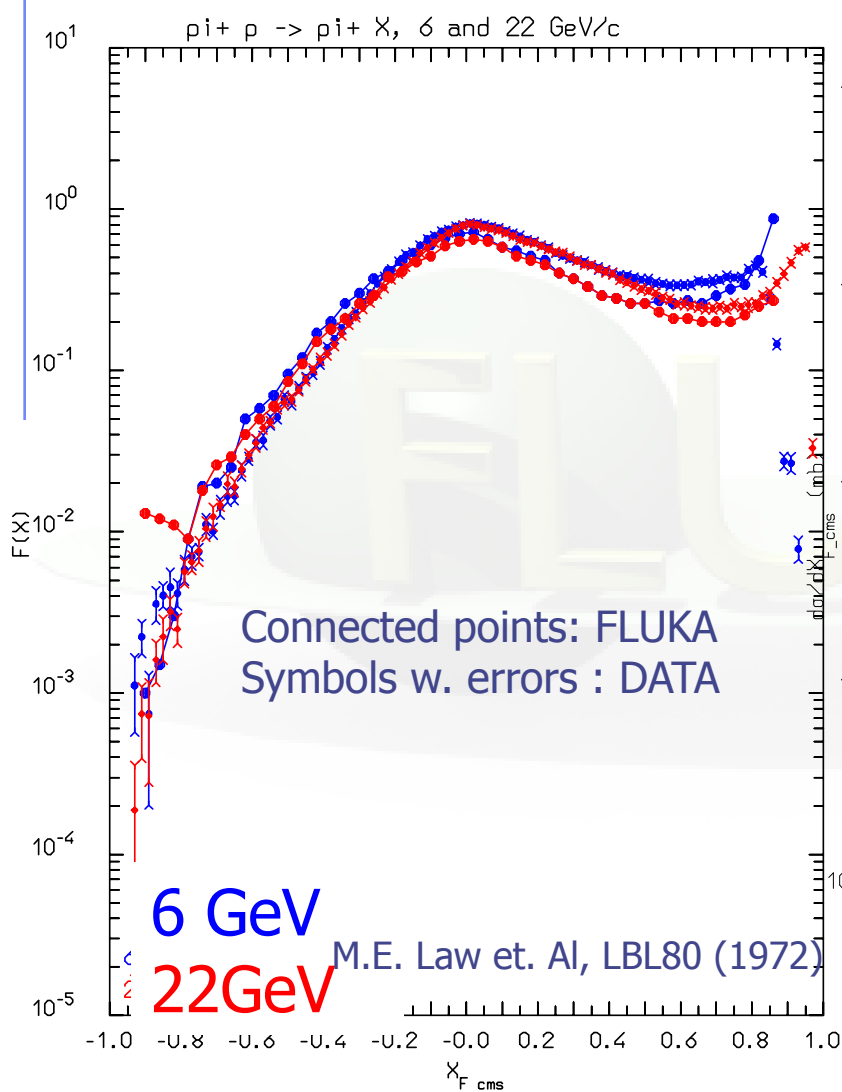

$$x_F = \frac{p_L}{p_{L\max}} = \frac{2p_L}{\sqrt{s}}$$

PEANUT

Target nucleus description (density, Fermi motion, etc)

Glauber-Gribov cascade with formation zone

Generalized IntraNuclear cascade

Preequilibrium stage
with current exciton configuration and excitation energy
(all non-nucleons emitted/decayed + all nucleons below 30-100 MeV)

*NB: above 5 GeV PEANUT is not the default
and must be explicitly selected!*

Evaporation/Fragmentation/Fission model

γ de-excitation

t (s)

10^{-23}

10^{-22}

10^{-20}

10^{-16}

WARNING

- PEANUT has been extended to cover the whole energy range in late 2006
- A less refined GINC model is available for projectile momenta above about 5 GeV/c, and was the only choice until recently
- However: the extended peanut is NOT yet the default, mainly because of some ambiguity in the definition of quasi-elastic cross sections.
- To activate PEANUT at all energies:

```
PHYSICS 1000. 1000. 1000. 1000. 1000. 1000. PEATHRESH
```

Nucleon Fermi Motion

- Fermi gas model: Nucleons = Non-interacting Constrained Fermions

Momentum distribution $\propto \frac{dN}{dk} = \frac{|k|^2}{2\pi^2}$

for k up to a (local) Fermi momentum $k_F(r)$ given by

$$k_F(r) = \left[3\pi^2 \rho_N(r) \right]^{\frac{1}{3}}$$

The Fermi energy ($k_F \approx 1.36$ fm, $P_F \approx 260$ MeV/c, $E_F \approx 35$ MeV, at nuclear max. density) is customarily used in building a self-consistent Nuclear Potential



Depth of the potential well \equiv **Fermi Energy + Nuclear Binding Energy**

Positive kaons as a probe of Fermi motion

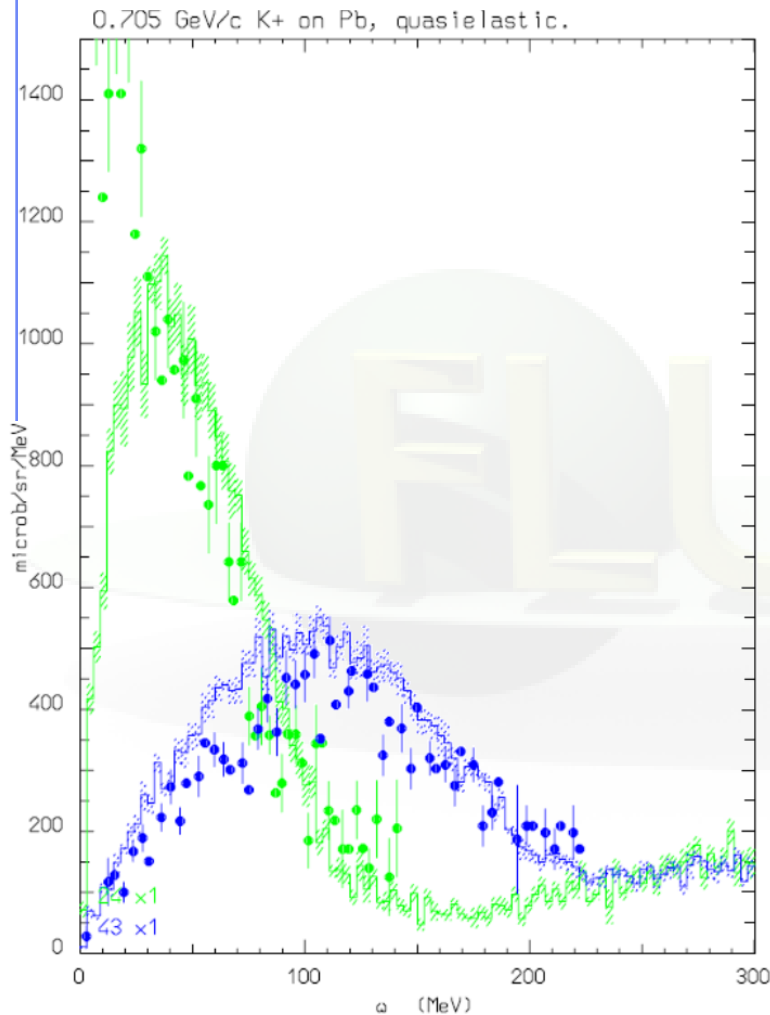

$$K^+ \quad K^0$$

No low mass $S=1$ baryons \rightarrow

weak K^+N interaction

only elastic and ch. exch. up to ≈ 800 MeV/c

(K^+ , K^{*+}) on Pb vs residual excitation, 705 MeV/c, at 24° and 43° .

Histo: FLUKA, dots: data (Phys Rev. C51, 669 (1995))

On free nucleon: recoil energy :
43 MeV at 24° , 117 MeV at 43° .

(Generalized) IntraNuclear Cascade

Some assets of the full GINC as implemented in FLUKA (PEANUT):

- Nucleus divided into **16 radial zones of different density**, plus **6** outside the nucleus to account for nuclear potential, plus **10** for charged particles
- **Different nuclear densities** (and Fermi energies) for neutrons and protons (shell model ones for $A \leq 16$)
- Nuclear (complex) optical potential → **curved trajectories** in the mean nuclear+Coulomb field (reflection, refraction)
- **Updating binding energy** (from mass tables) after each particle emission
- **Multibody** absorption for π^{+0-} K^{-0} μ^{-}
- Exact **energy-momentum conservation** including the recoil of the residual nucleus and experimental binding energies
- Nucleon **Fermi motion** including wavepacket-like uncertainty smearing, (approximate) nucleon-nucleon, and $r \leftrightarrow E_f(r)$ correlations
- **Quantum effects** (mostly suppressive): **Pauli blocking**, **Formation zone**, **Nucleon antisymmetrization**, **Nucleon-nucleon hard-core correlations**, **Coherence length**

hA at high energies: Glauber-Gribov cascade with formation zone

- Glauber cascade
 - Quantum mechanical method to compute Elastic, Quasi-elastic and Absorption hA cross sections from **Free hadron-nucleon scattering + nuclear ground state**
 - **Multiple Collision** expansion of the scattering amplitude
- Glauber-Gribov
 - **Field theory** formulation of Glauber model
 - Multiple collisions \leftrightarrow **Feynman diagrams**
 - High energies: exchange of one or more Pomerons with one or more target nucleons (a closed string exchange)
- Formation zone (=materialization time)

Gribov interpretation of Glauber multiple collisions

The absorption cross section is just the integral in the impact parameter plane of the probability of getting at least one non-elastic hadron-nucleon collision, and it is naturally written in a multiple collision expansion

with the overall average number of collisions given by

$$\langle \nu \rangle = \frac{Z\sigma_{hpr} + N\sigma_{hnr}}{\sigma_{hAabs}}$$

- Glauber-Gribov model = Field theory formulation of Glauber model
- Multiple collision terms \Rightarrow Feynman graphs
- At high energies : exchange of one or more Pomerons with one or more target nucleons
- In the Dual Parton Model language (neglecting higher order diagrams):
Interaction with n target nucleons $\Rightarrow 2n$ chains
 - Two chains from projectile valence quarks + valence quarks of one target nucleon $\Rightarrow 2$ valence-valence chains
 - $2(n-1)$ chains from sea quarks of the projectile + valence quarks of target nucleons $\Rightarrow 2(n-1)$ sea-valence chains

Chain examples

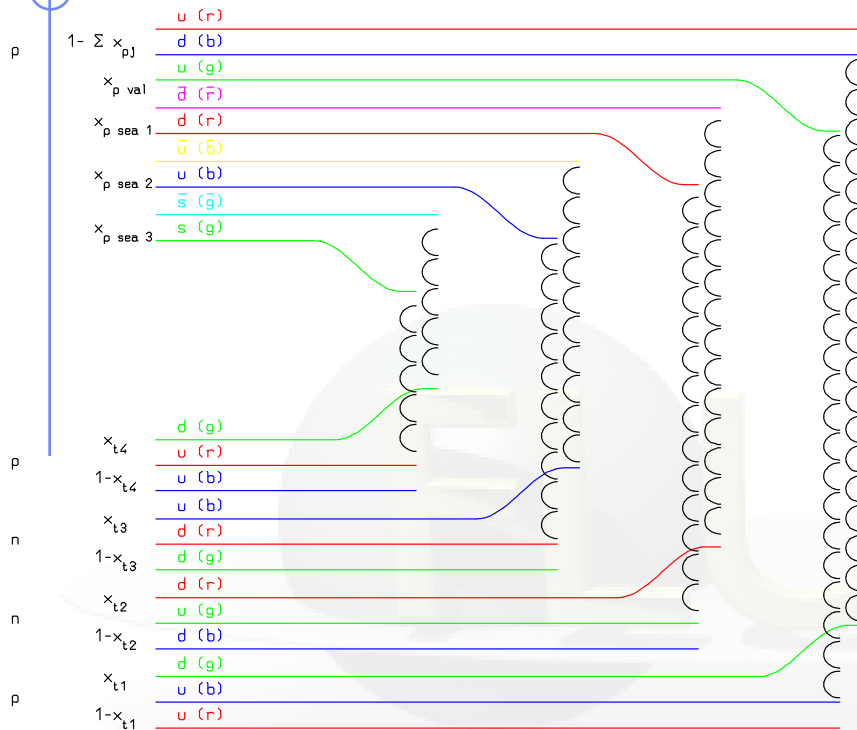

Leading two-chain diagram in DPM for **p-A Glauber scattering** with 4 collisions

The color (red, antired, blue, antiblue, green, and antigreen) and quark combination shown in the figure is just one of the allowed possibilities

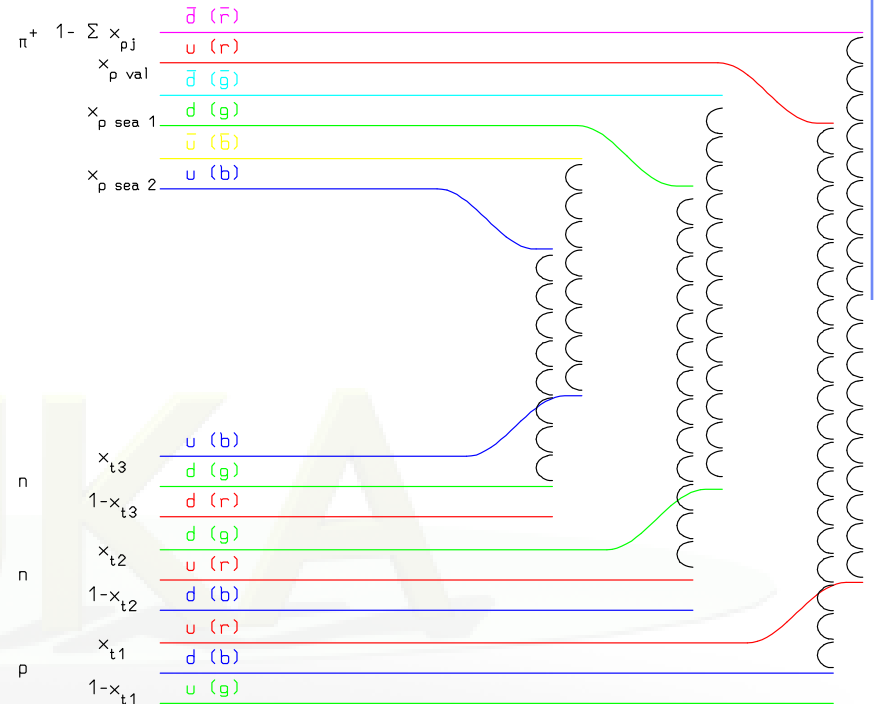

Leading two-chain diagram in DPM for **π^+ -A Glauber scattering** with 3 collisions

The color (red, antired, blue, antiblue, green, and antigreen) and quark combination shown in the figure is just one of the allowed possibilities

Formation zone

Classical INC will never work

J.Ranft applied the concept, originally proposed by Stodolski, to hA and AA nuclear int.

Naively: "materialization" time

Qualitative estimate:

In the frame where $p_{||} = 0$

$$\bar{t} = \Delta t \approx \frac{\hbar}{E_T} = \frac{\hbar}{\sqrt{p_T^2 + M^2}}$$

Particle proper time

$$\tau = \frac{M}{E_T} \bar{t} = \frac{\hbar M}{p_T^2 + M^2}$$

Going to the nucleus system

$$\Delta x_{for} \equiv \beta c \cdot t_{lab} \approx \frac{p_{lab}}{E_T} \bar{t} \approx \frac{p_{lab}}{M} \tau = k_{for} \frac{\hbar p_{lab}}{p_T^2 + M^2}$$

Condition for possible re-interaction inside a nucleus:

$$\Delta x_{for} \leq R_A \approx r_0 A^{\frac{1}{3}}$$

no Glauber, no formation zone

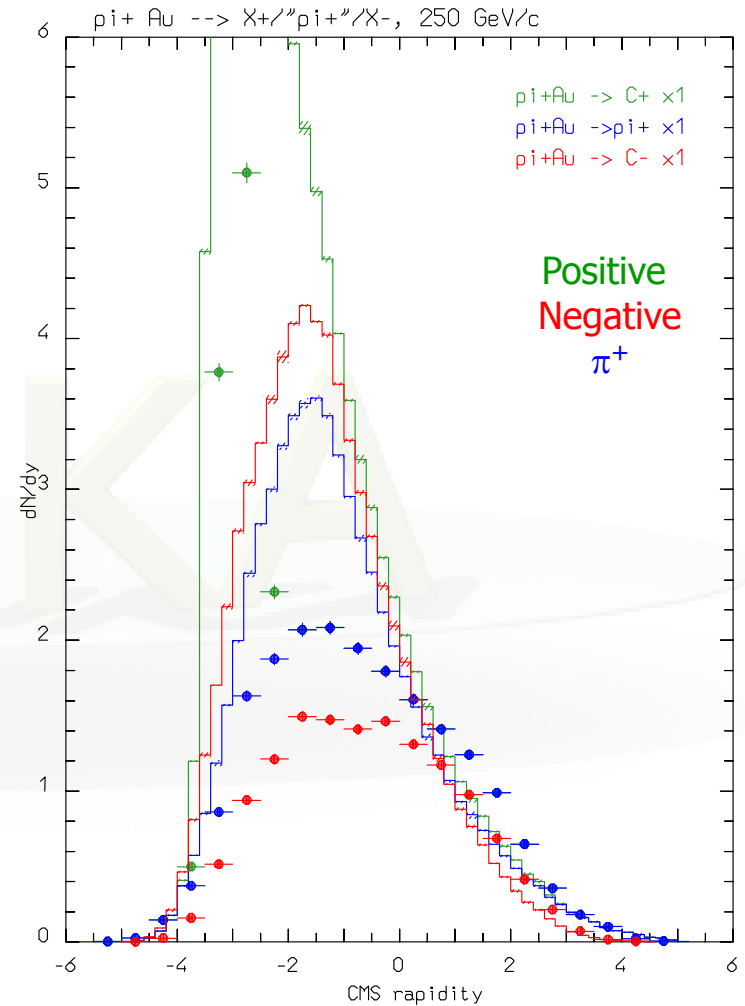
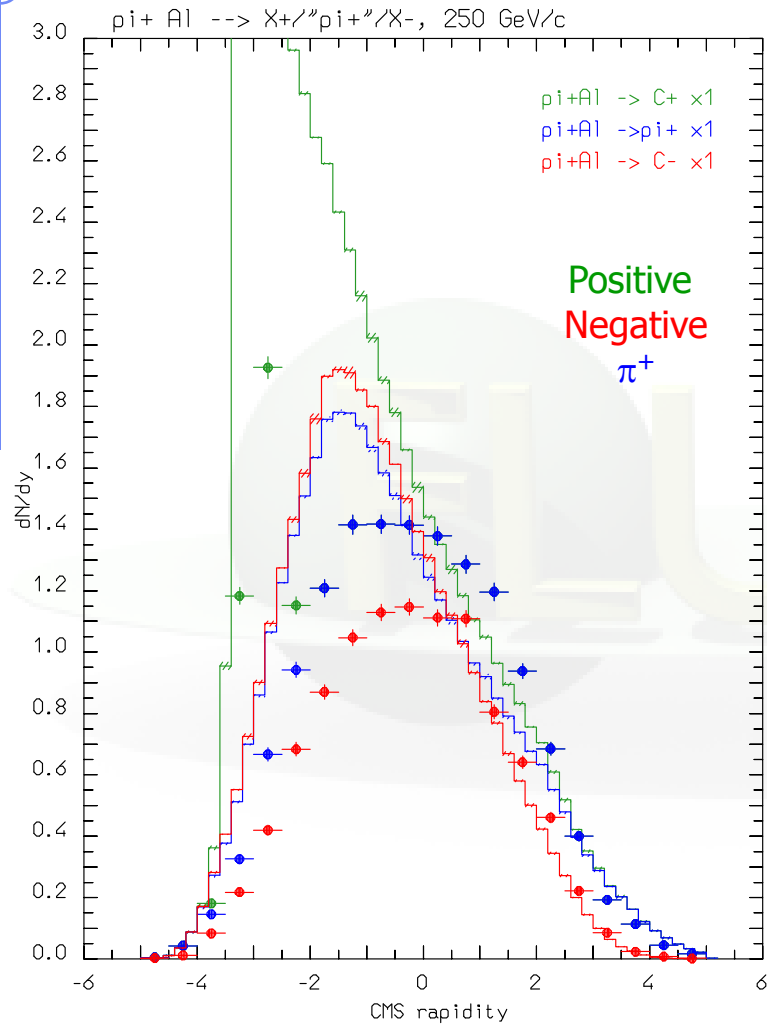

Rapidity distributions of charged particles produced in 250 GeV π^+ collisions on Aluminum (left) and Gold (right)
Points: exp. data (Agababyan et al., ZPC50, 361 (1991))

no Glauber, yes formation zone

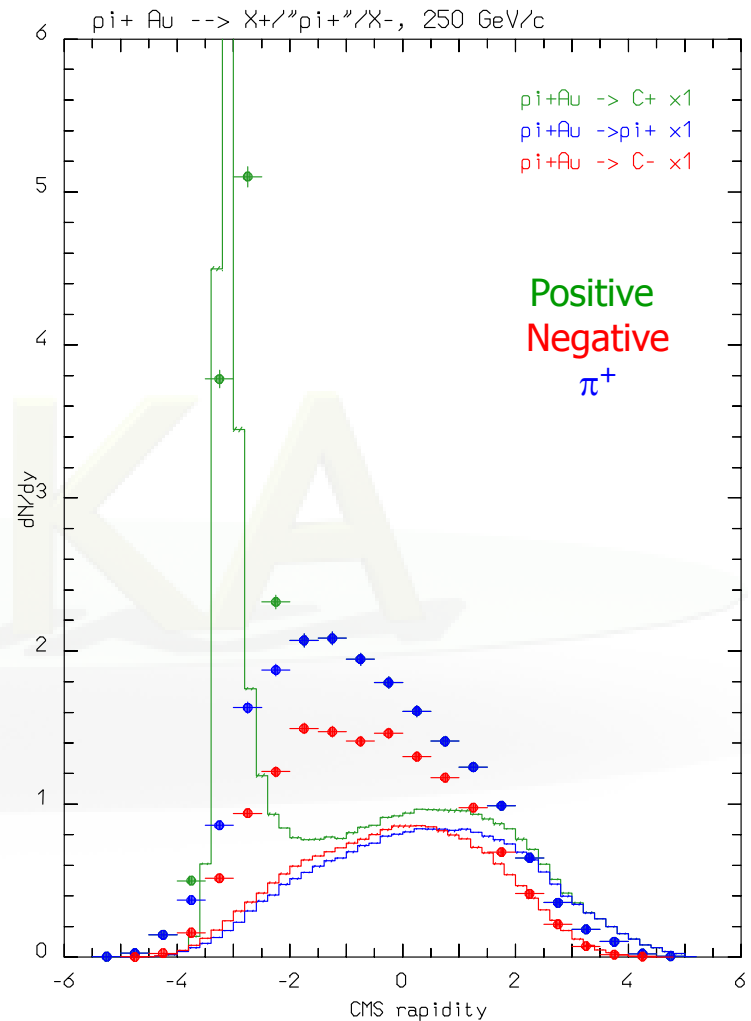
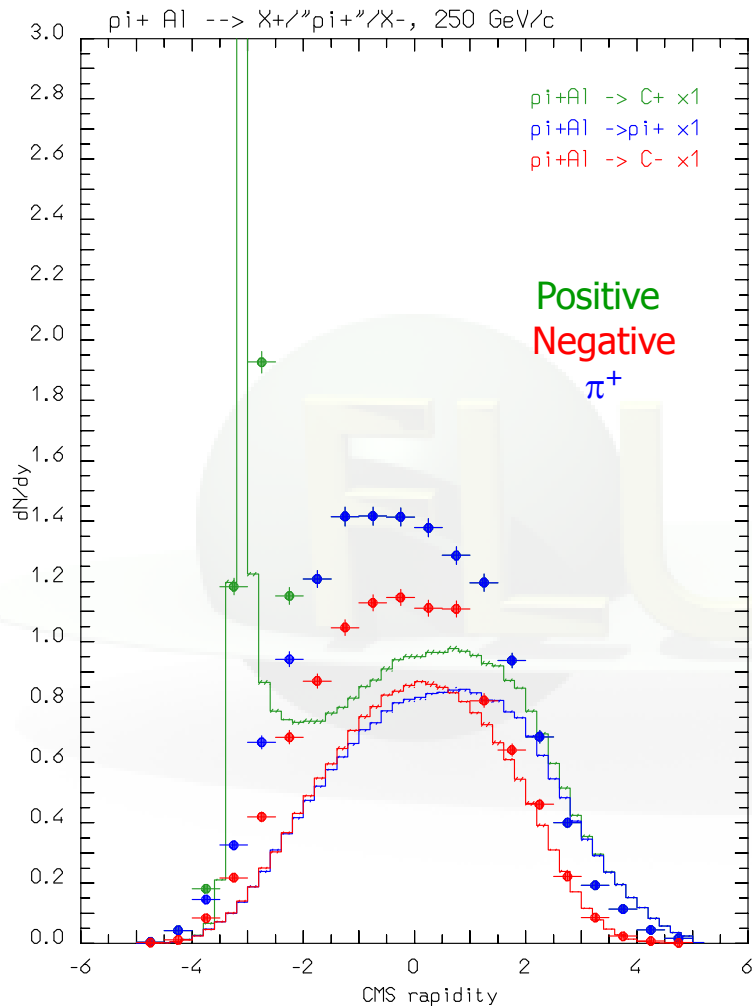

Rapidity distributions of charged particles produced in 250 GeV π^+ collisions on Aluminum (left) and Gold (right)
Points: exp. data (Agababyan et al., ZPC50, 361 (1991))

yes Glauber, no formation zone

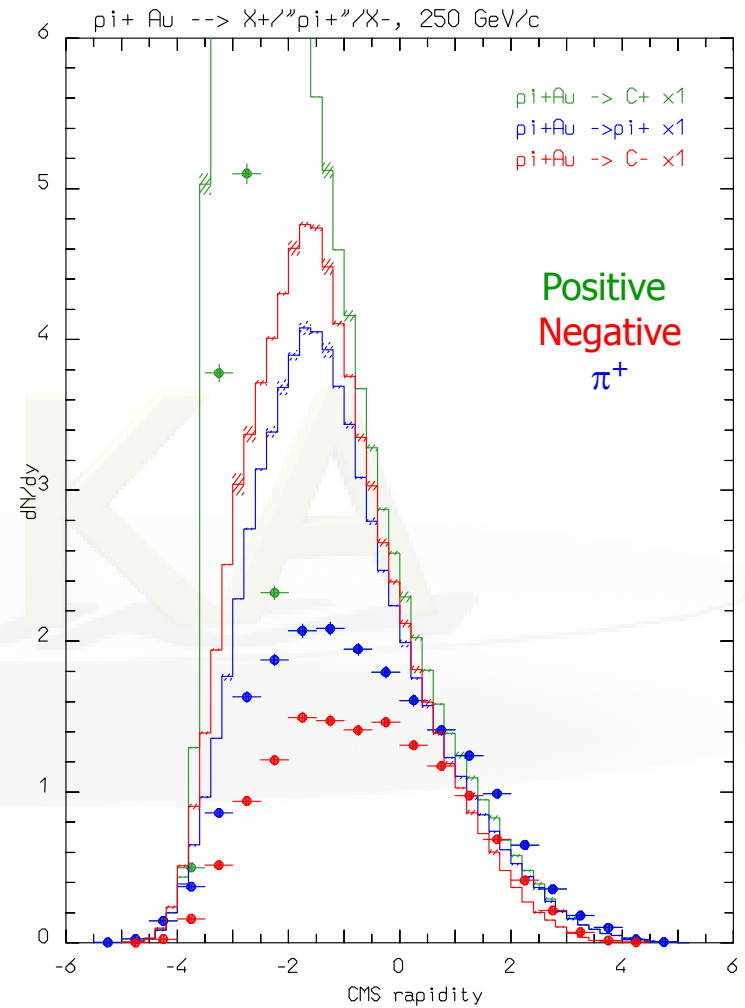
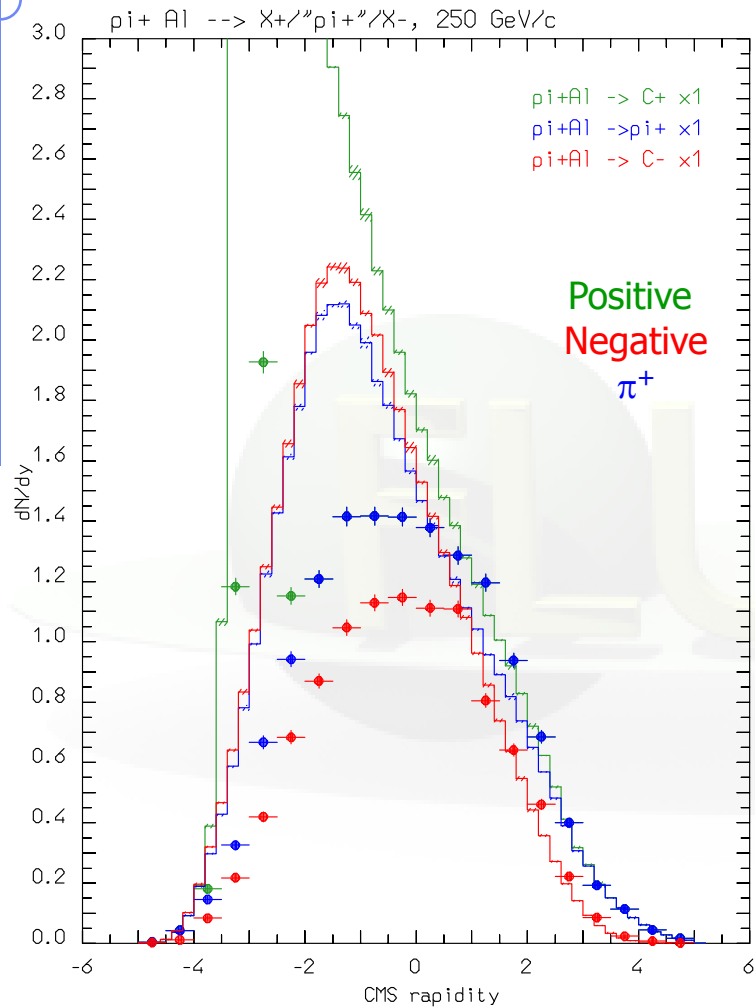

Rapidity distributions of charged particles produced in 250 GeV π^+ collisions on Aluminum (left) and Gold (right)
Points: exp. data (Agababyan et al., ZPC50, 361 (1991))

yes Glauber, yes formation zone

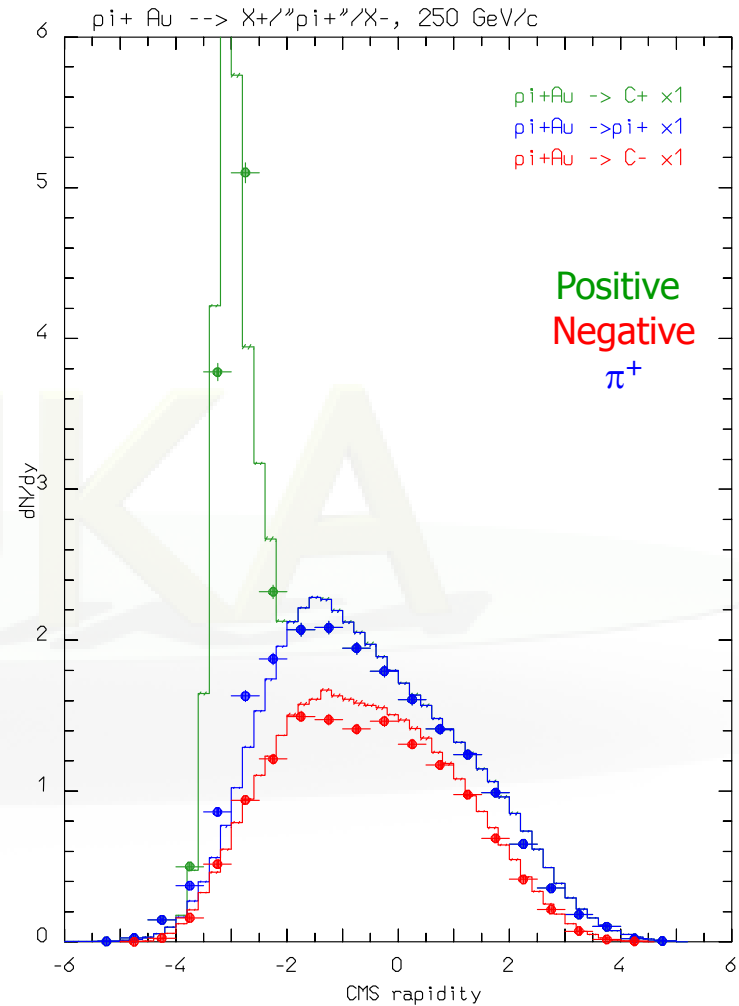
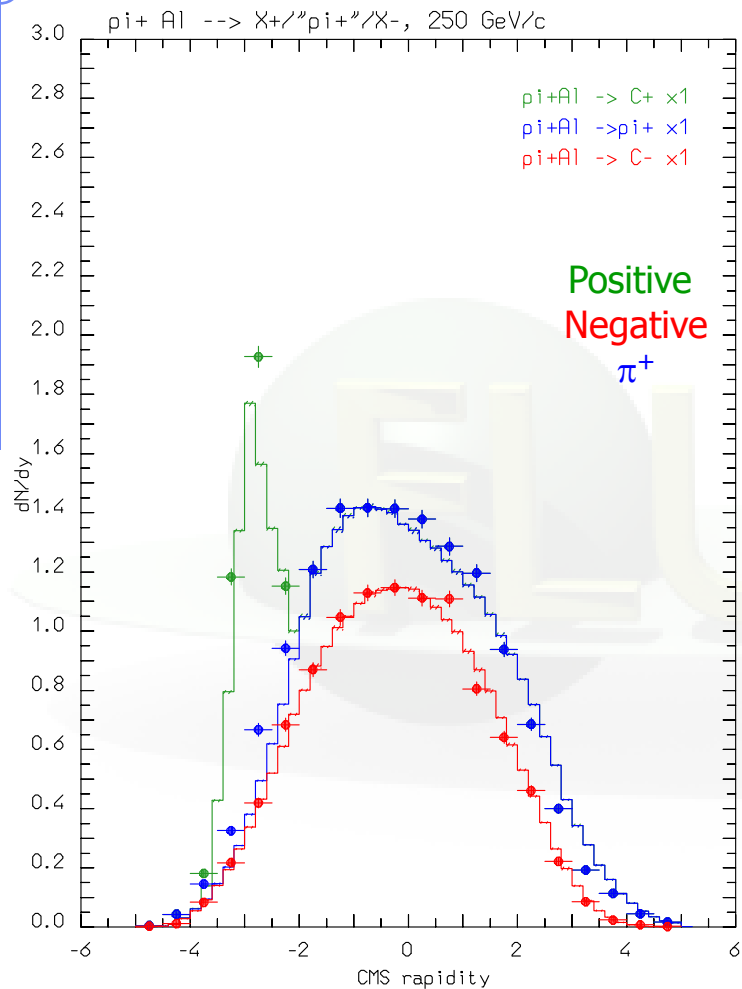

Rapidity distributions of charged particles produced in 250 GeV π^+ collisions on Aluminum (left) and Gold (right)
Points: exp. data (Agababyan et al., ZPC50, 361 (1991))

Nonelastic hA interactions at high energies: examples

Harp expt. , 12.9 GeV/c p on Al

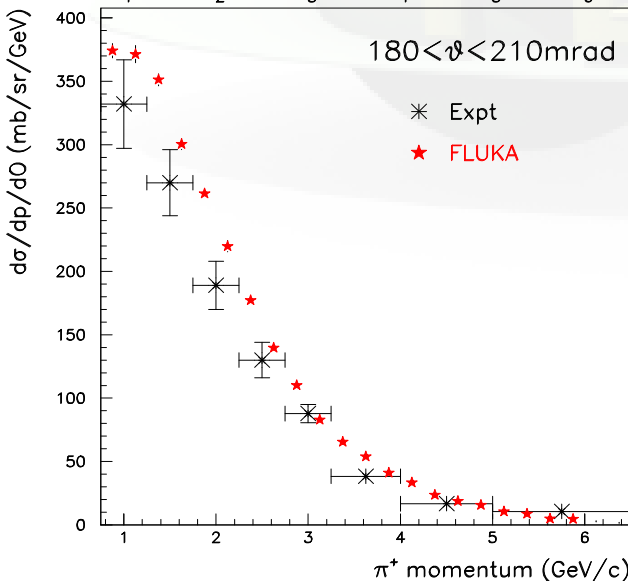
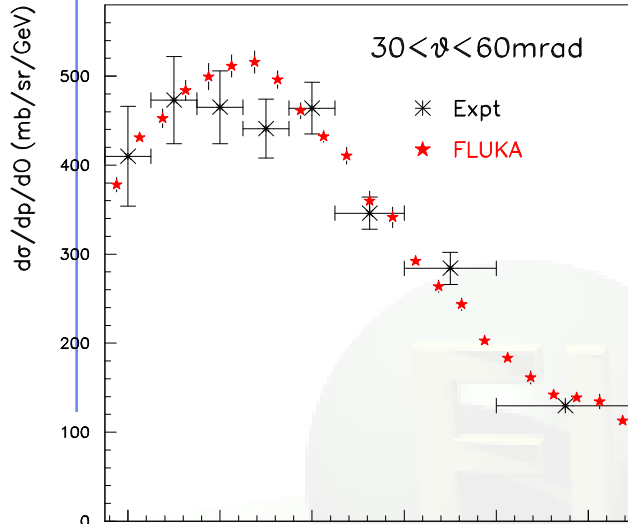

NA49 expt. , 158 GeV/c p on C

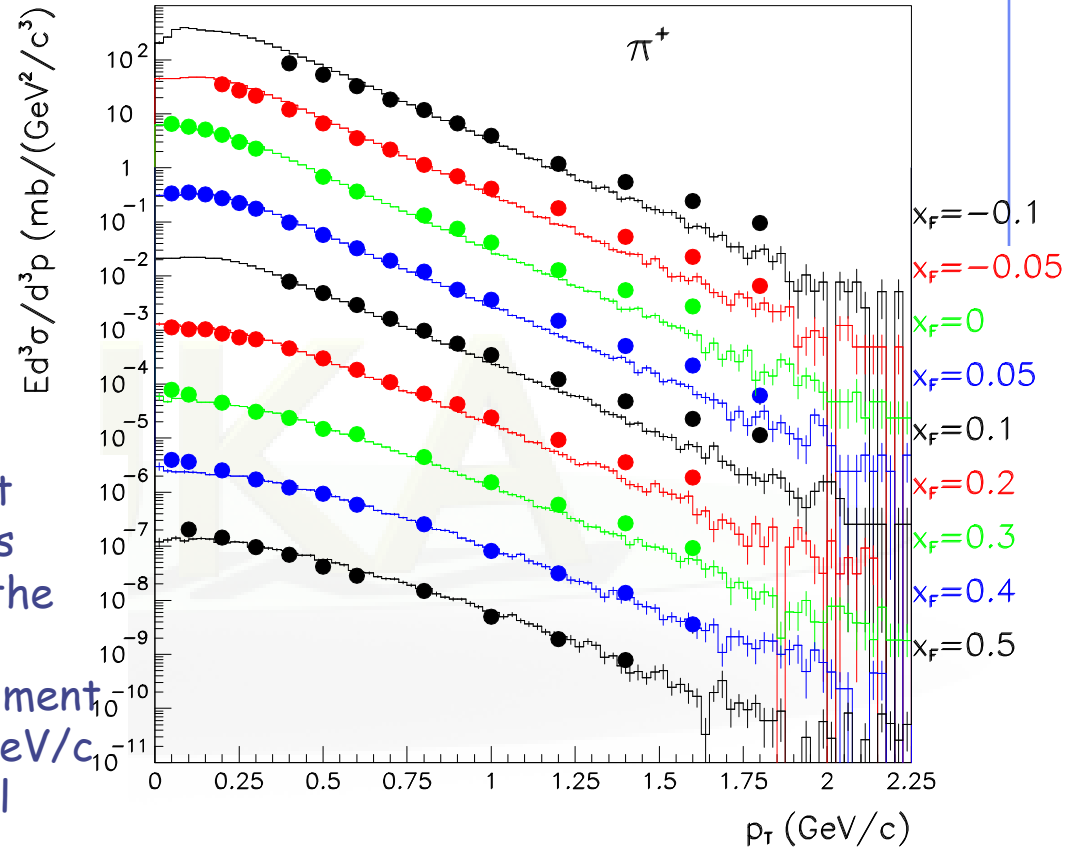

Recent results from the HARP experiment 12.9 GeV/c p on Al π^+ production at different angles

Double differential π^+ production for p C interactions at 158 GeV/c, as measured by NA49 (symbols) and predicted by FLUKA (histograms)

Double differential pion production

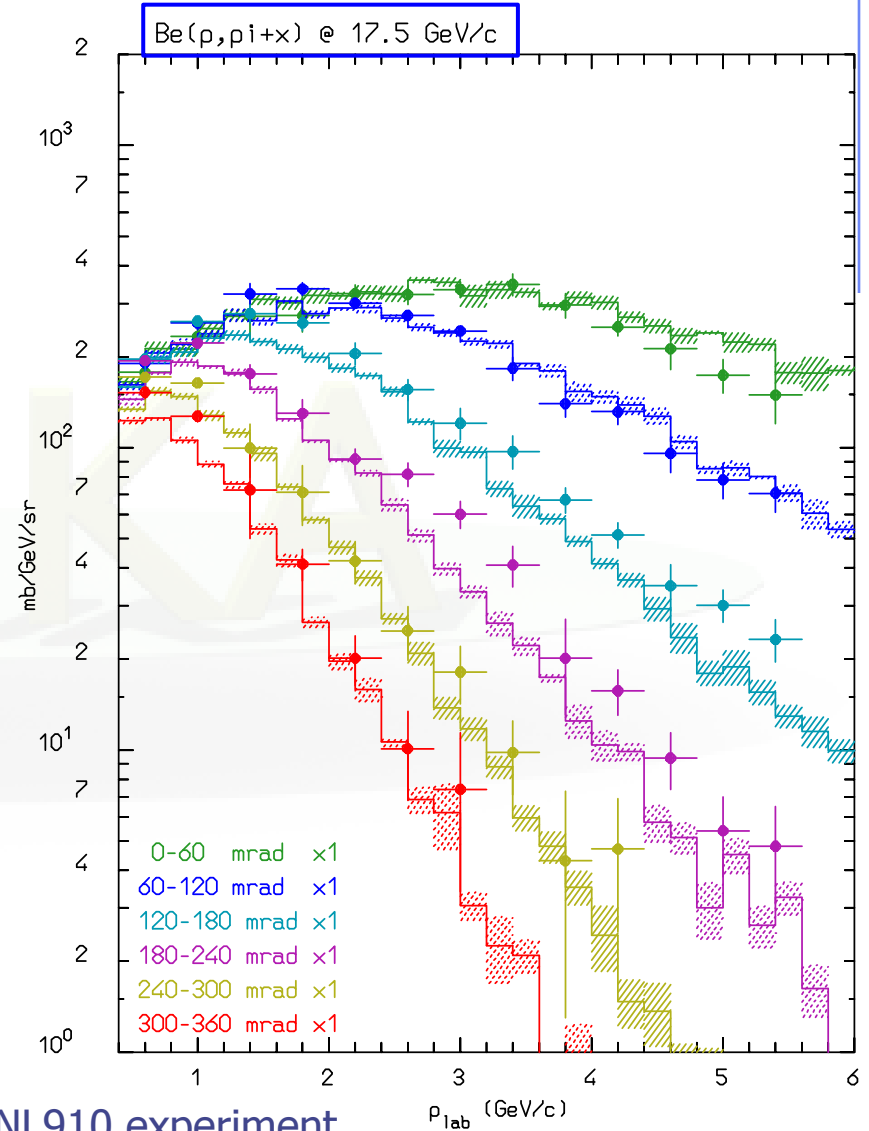
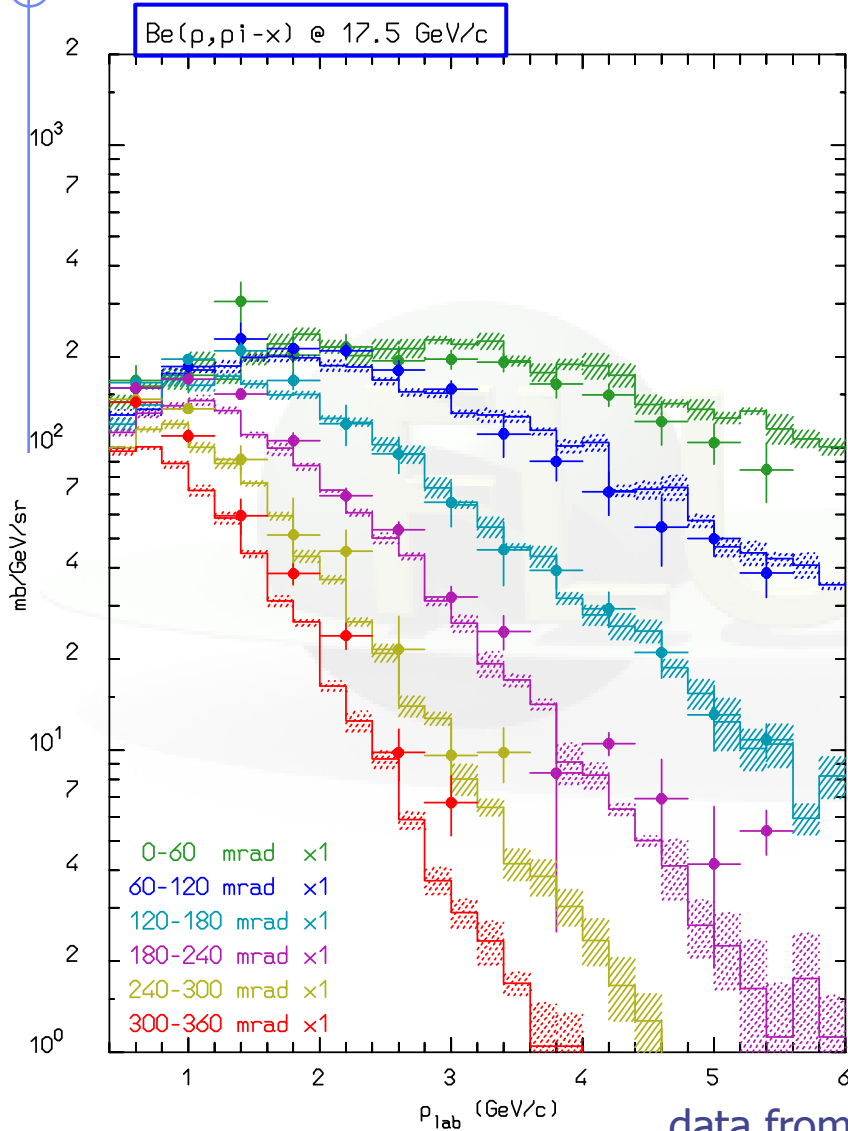

data from BNL910 experiment

Double differential pion production

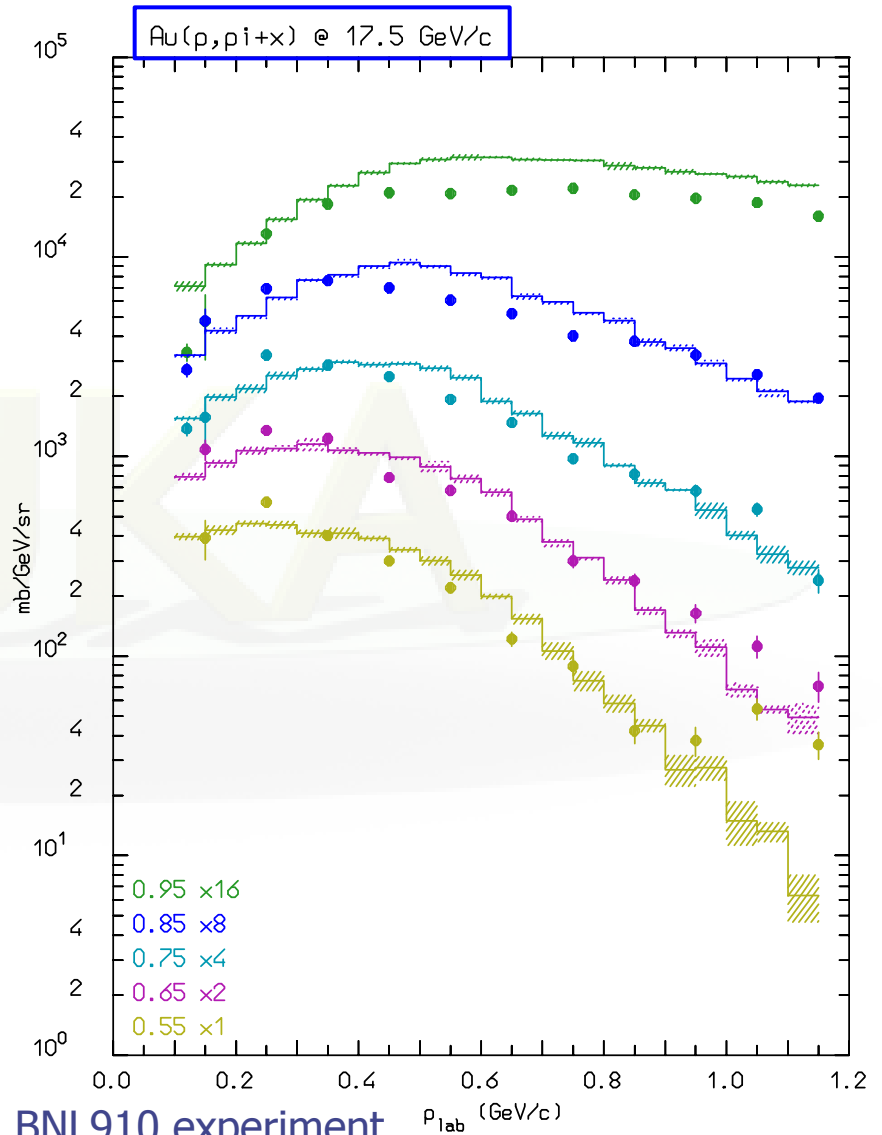
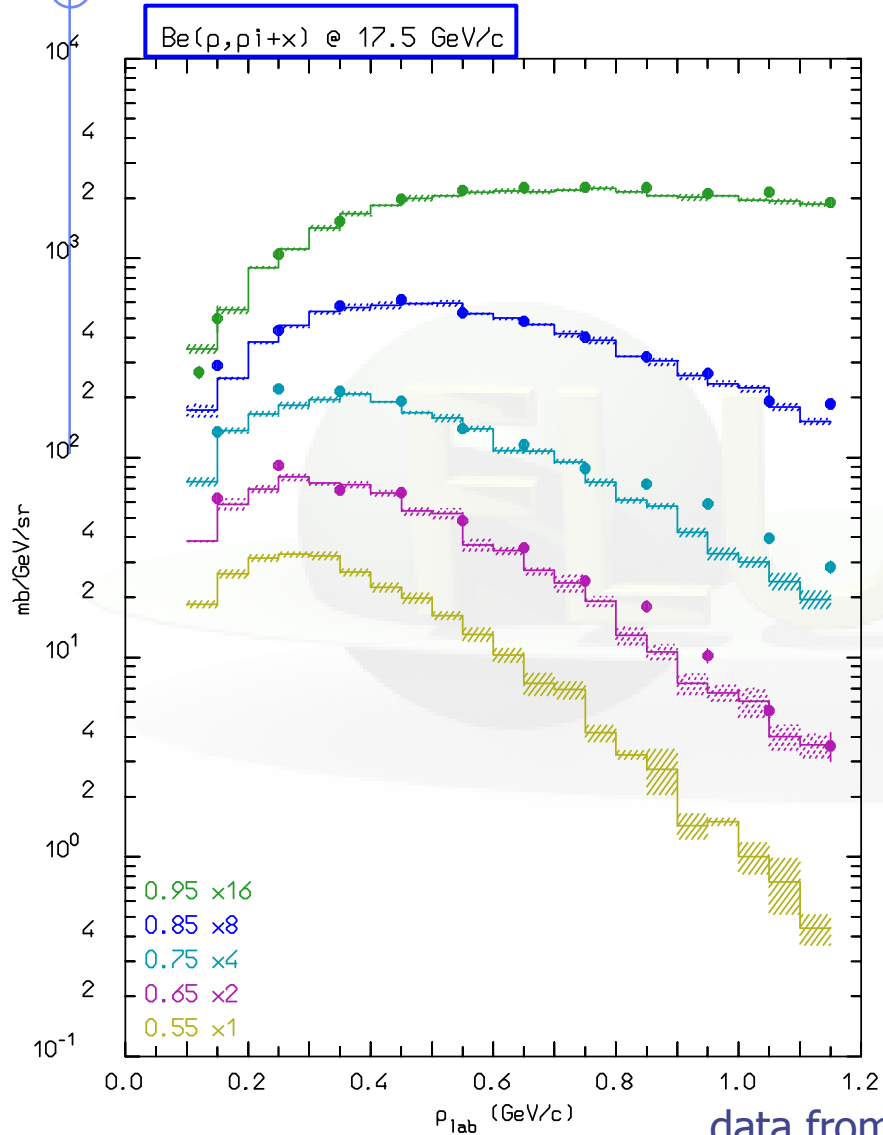

data from BNL910 experiment

Double differential pion production

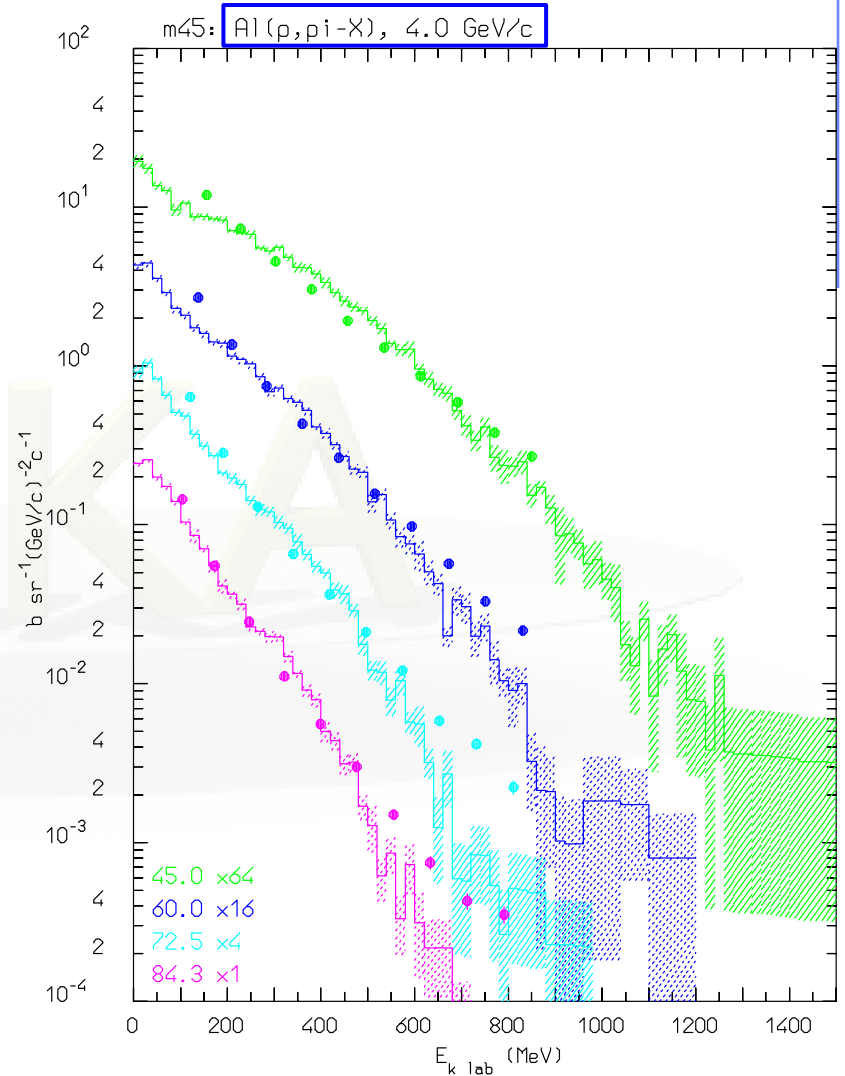
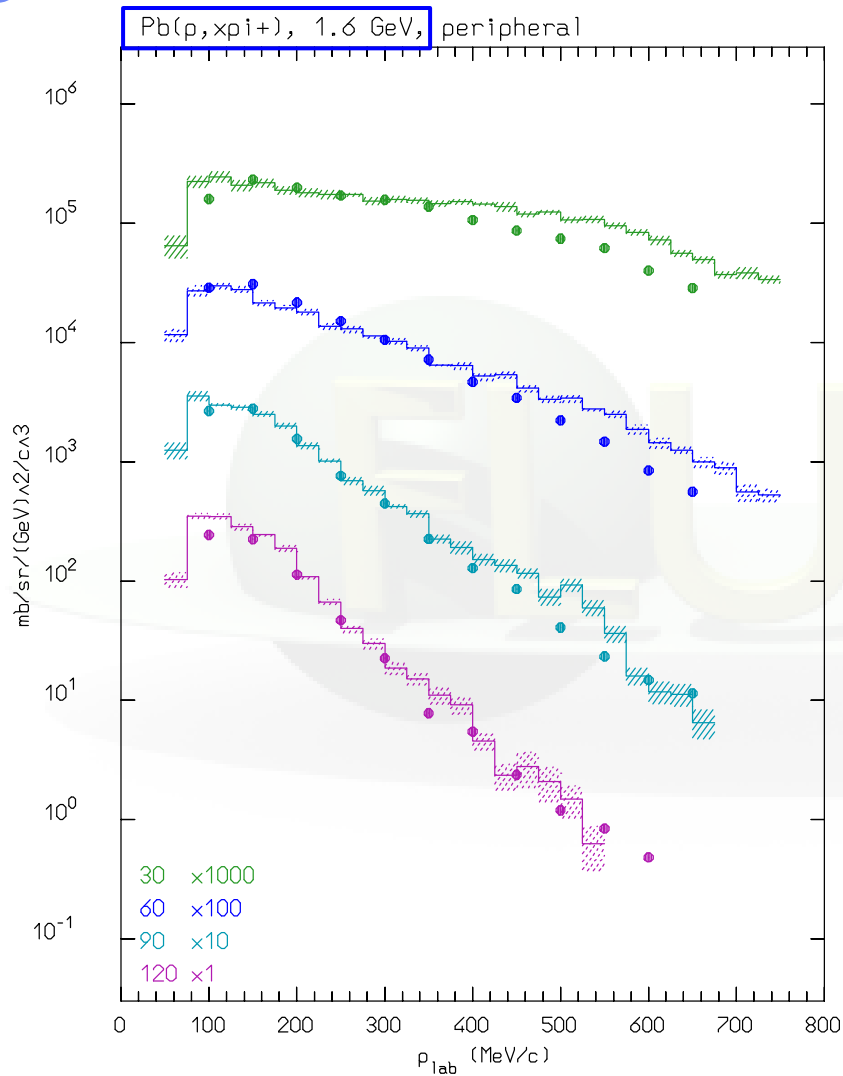

Pions: nuclear medium effects

Free πN interactions \Rightarrow \Rightarrow Non resonant channel
 \Rightarrow P-wave resonant Δ production

Δ in nuclear medium \Rightarrow decay \Rightarrow elastic scattering, charge exchange
 \Rightarrow reinteraction \Rightarrow Multibody pion absorption

Assuming for the free resonant σ a Breit-Wigner form with width Γ_F

$$\sigma_{res}^{Free} = \frac{8\pi}{p_{cms}^2} \frac{M_{\Delta}^2 \Gamma_F^2(p_{cms})}{(s - M_{\Delta}^2)^2 + M_{\Delta}^2 \Gamma_F^2(p_{cms})}$$

An "in medium" resonant σ (σ_{res}^A) can be obtained adding to Γ_F the imaginary part of the (extra) width arising from nuclear medium

$$\frac{1}{2}\Gamma_T = \frac{1}{2}\Gamma_F - \text{Im}\Sigma_{\Delta} \quad \Sigma_{\Delta} = \Sigma_{qe} + \Sigma_2 + \Sigma_3 \quad (\text{Oset et al., NPA 468, 631})$$

quasielastic scattering, two and three body absorption

The in-nucleus σ_t^A takes also into account a two-body s-wave absorption σ_s^A derived from the optical model

$$\sigma_t^A = \sigma_{res}^A + \sigma_t^{Free} - \sigma_{res}^{Free} + \sigma_s^A \quad \sigma_s^A(\omega) = \frac{4\pi}{p} \left(1 + \frac{\omega}{2m}\right) \text{Im} B_0(\omega) \rho$$

Pion absorption

Pion absorption cross section on Gold and Bismuth in the Δ resonance region (multibody absorption in PEANUT)

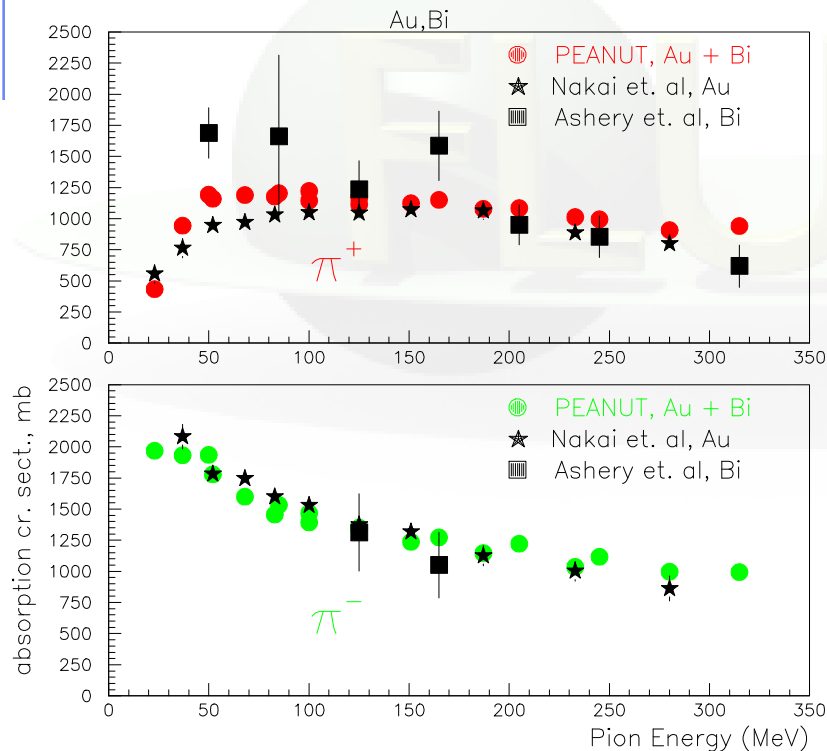

Emitted proton spectra at different angles, 160 MeV π^+ on ^{58}Ni

Phys. Rev. C41,2215 (1990)

Phys. Rev. C24,211 (1981)

Proton spectra extend up to 300 MeV

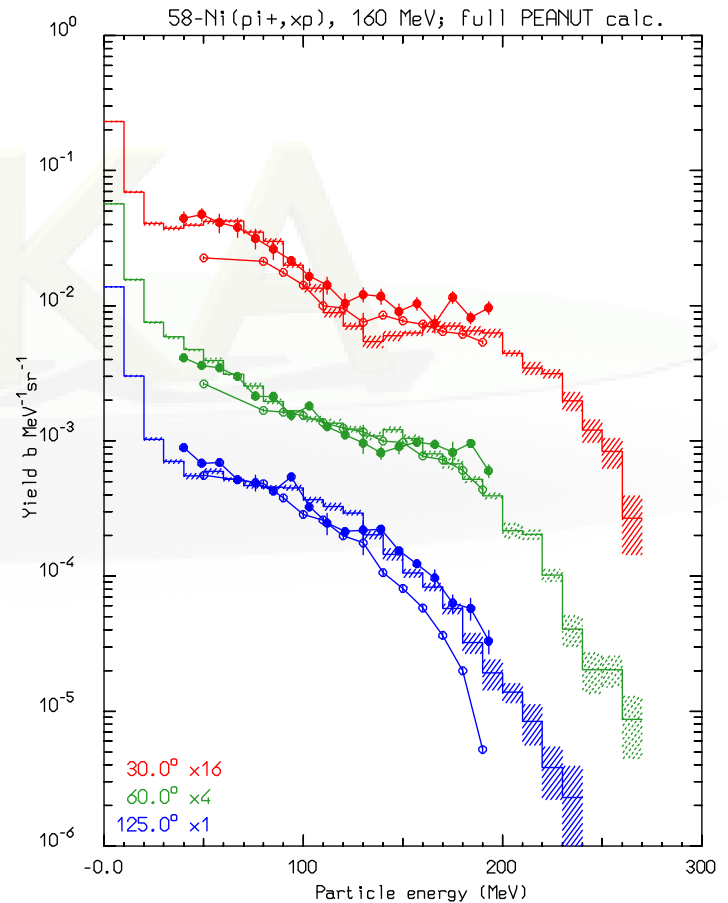

Coalescence

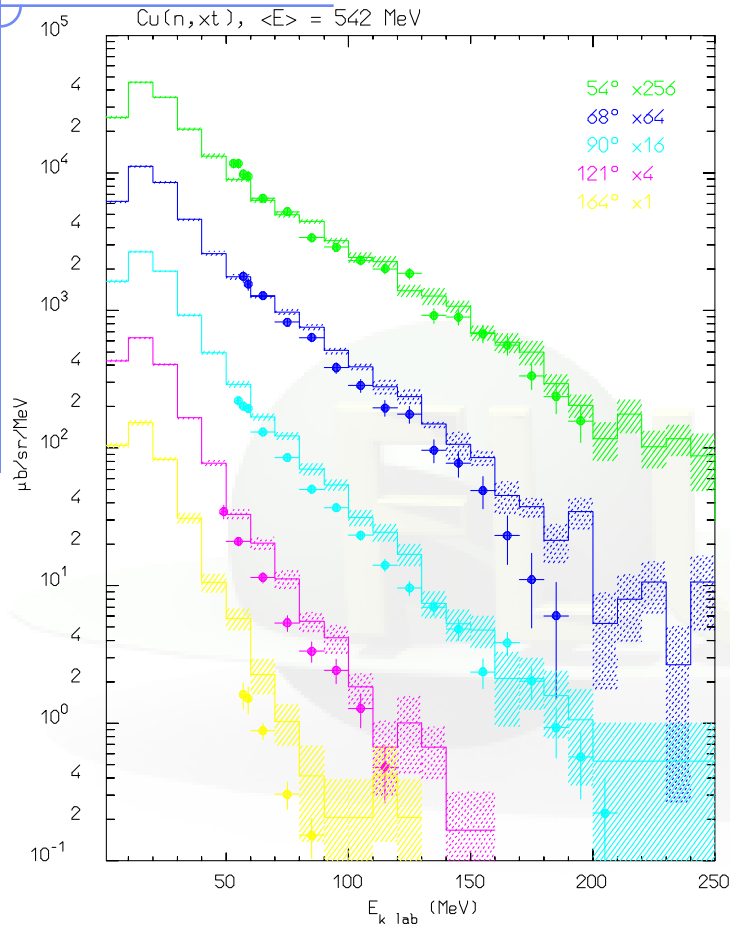

High energy light fragments are emitted through the coalescence mechanism: "put together" emitted nucleons that are near in phase space.

Example : double differential π production from 542 MeV neutrons on Copper

Warning: coalescence is OFF by default
Can be important, ex for . residual nuclei.
To activate it:

Preequilibrium emission

For $E > \pi$ production threshold \rightarrow only (G)INC models
At lower energies a variety of preequilibrium models

Two leading approaches

The quantum-mechanical multistep model:
Very good theoretical background
Complex, difficulties for multiple emissions

The semiclassical exciton model
Statistical assumptions
Simple and fast
Suitable for MC



Statistical assumption:

any partition of the excitation energy E^* among N , $N = N_n + N_p$, excitons has the same probability to occur

Step: nucleon-nucleon collision with $N_{n+1} = N_n + 2$ ("never come back approximation")

Chain end = equilibrium = N_n sufficiently high or excitation energy below threshold

N_1 depends on the reaction type and cascade history

Thin target example

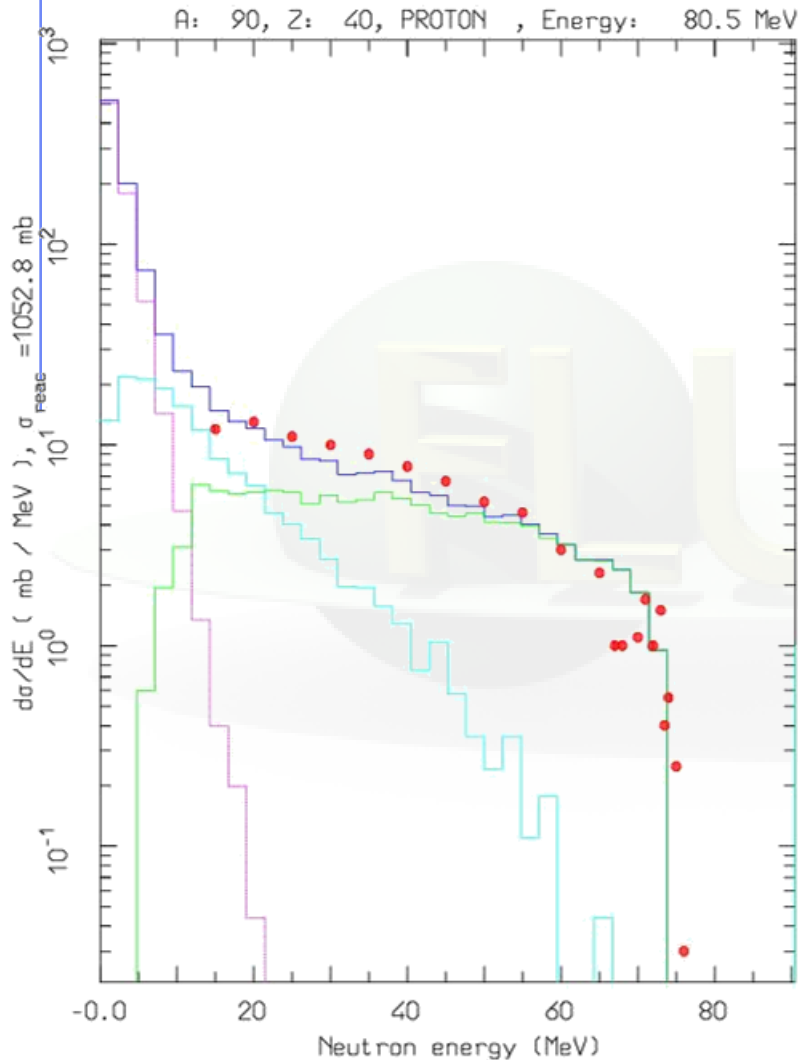

Angle-integrated $^{90}\text{Zr}(p,xn)$ at 80.5 MeV

The various lines show the total, INC, preequilibrium and evaporation contributions

Experimental data from M. Trabandt et al., Phys. Rev. C39, 452 (1989)

Thin target examples

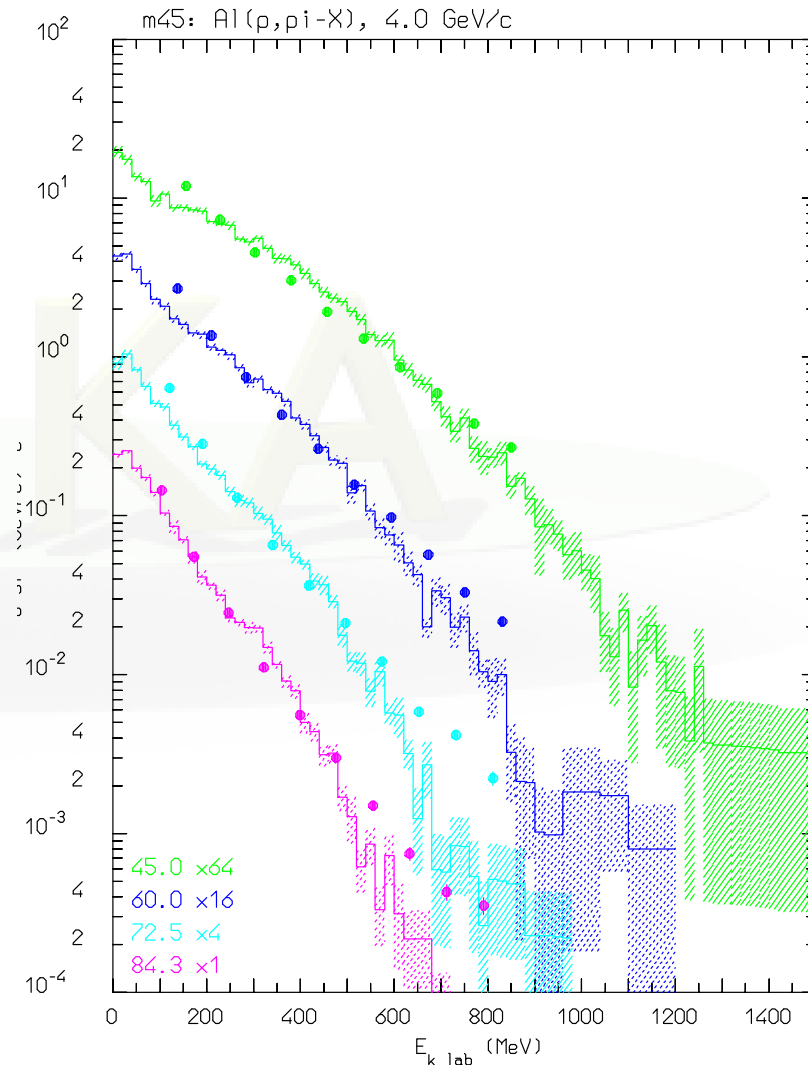
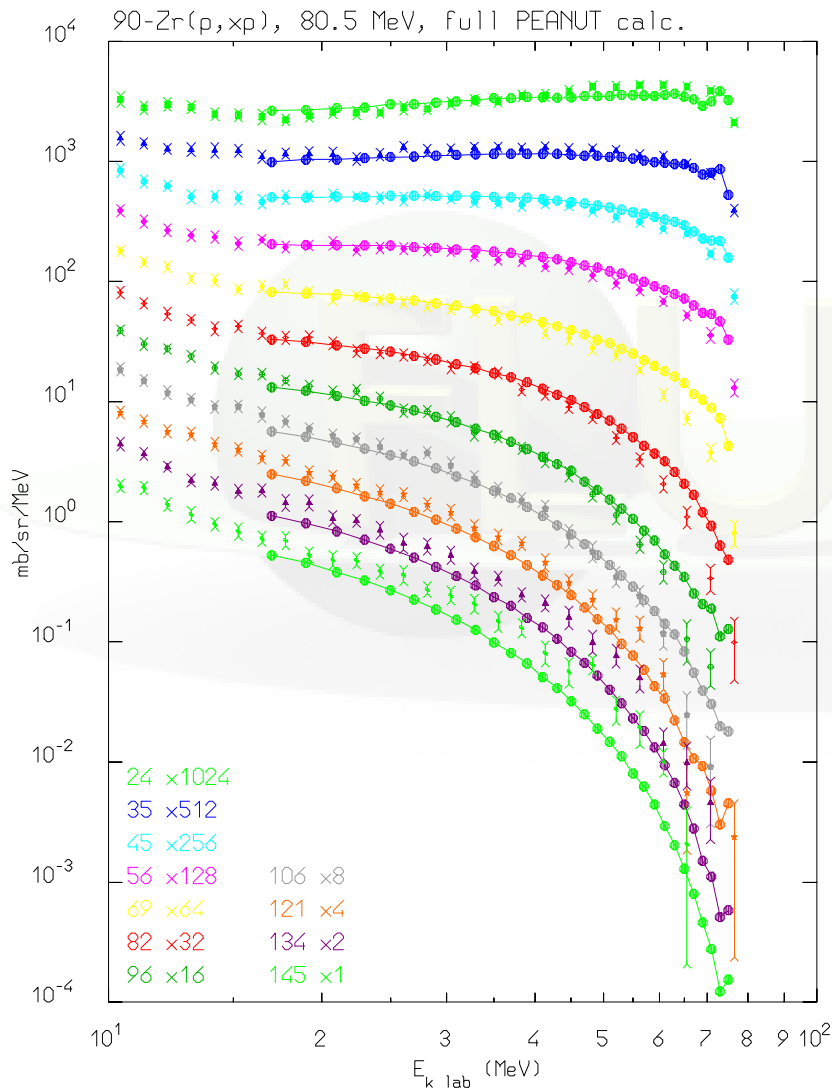

Equilibrium particle emission (evaporation, fission and nuclear break-up)

From statistical considerations and the detailed balance principle, the probabilities for emitting a particle of mass m_j , spin $S_j \hbar$ and energy E , or of fissioning are given by:

(i, f for initial/final state, **Fiss** for fission saddle point)

Probability per unit time of emitting a particle j with energy E

$$P_J = \frac{(2S_j + 1)m_j c}{\pi^2 \hbar^3} \int_{V_j}^{U_i - Q_j - \Delta_f} \frac{\rho_f(U_f)}{\rho_i(U_i)} \sigma_{inv}(E) E dE$$

Probability per unit time of fissioning

$$P_{Fiss} = \frac{1}{2\pi\hbar} \int_0^{U_i - B_{Fiss}} \frac{\rho_{Fiss}(U_i - B_{Fiss} - E)}{\rho_i(U_i)} dE$$

- ρ 's: nuclear level densities
- U 's: excitation energies
- V_j 's: possible Coulomb barrier for emitting a particle type j
- B_{Fiss} : fission barrier

- Q_j 's: reaction Q for emitting a particle type j
- σ_{inv} : cross section for the inverse process
- Δ 's: pairing energies

*Neutron emission is strongly favoured because of the lack of any barrier
Heavy nuclei generally reach higher excitations because of more intense cascading*

Equilibrium particle emission

- Evaporation: Weisskopf-Ewing approach
 - ~600 possible emitted particles/states ($A < 25$) with an extended evaporation/fragmentation formalism
 - Full level density formula with level density parameter A, Z and excitation dependent
 - Inverse cross section with proper sub-barrier
 - Analytic solution for the emission widths (neglecting the level density dependence on U , taken into account by rejection)
 - Emission energies from the width expression with no. approx.
- Fission: past, improved version of the Atchison algorithm, now
 - Γ_{fis} based of first principles, full competition with evaporation
 - Improved mass and charge widths
 - Myers and Swiatecki fission barriers, with exc. en. Dependent level density enhancement at saddle point
- Fermi Break-up for $A < 18$ nuclei
 - ~ 50000 combinations included with up to 6 ejectiles
 - γ de-excitation: statistical + rotational + tabulated levels

Residual Nuclei

- The production of residuals is the result of the last step of the nuclear reaction, thus it is influenced by all the previous stages
- Residual mass distributions are very well reproduced
- Residuals near to the compound mass are usually well reproduced
- However, the production of specific isotopes may be influenced by additional problems which have little or no impact on the emitted particle spectra (Sensitive to details of evaporation, Nuclear structure effects, Lack of spin-parity dependent calculations in most MC models)

$\text{Log}_{10} N$ of residual nuclei

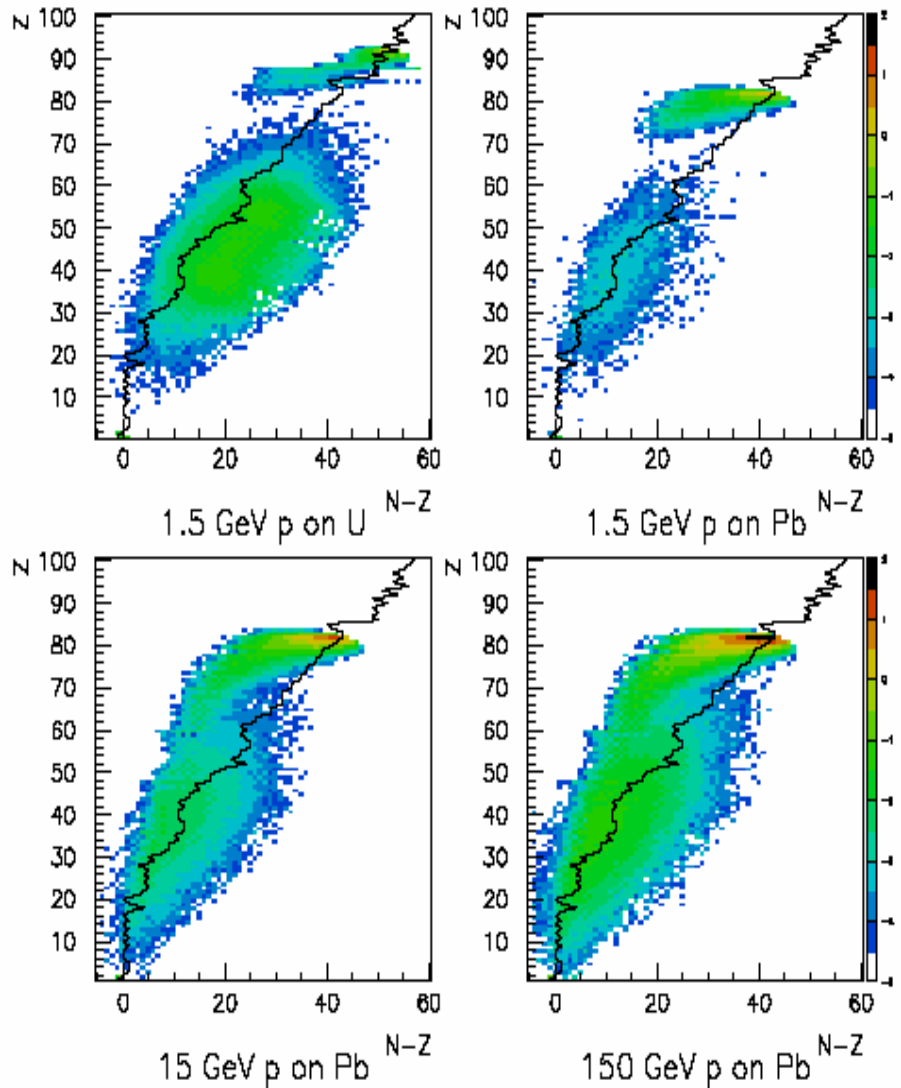

Example of fission/evaporation

1 A GeV $^{208}\text{Pb} + \text{p}$ reactions Nucl. Phys. A 686 (2001) 481-524

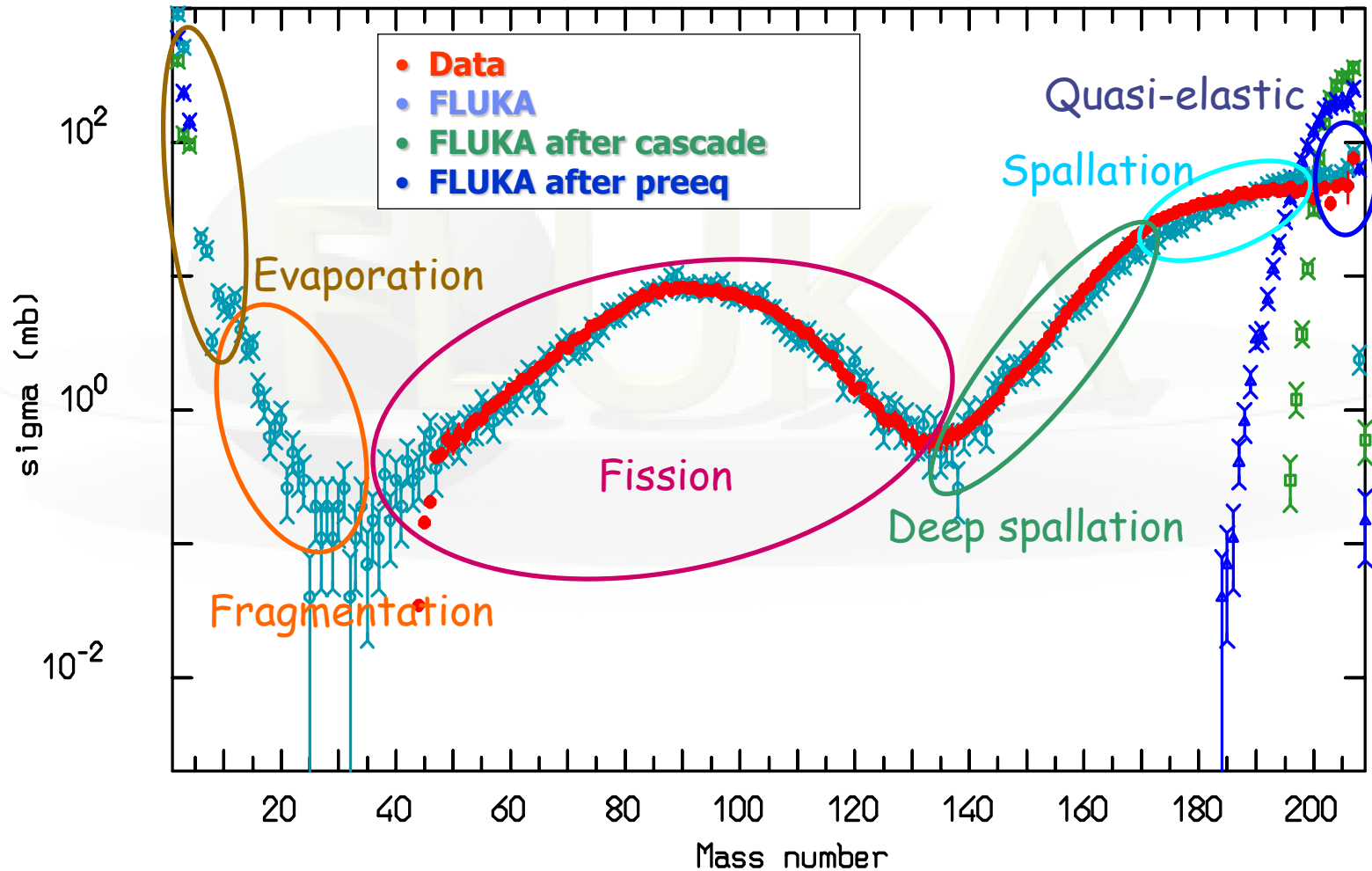

Residual nuclei

Experimental and computed residual nuclei mass distribution for $Ag(p,x)X$ at 300 GeV

Data from Phys. Rev. C19 2388 (1979) and Nucl. Phys. A543, 703 (1992)

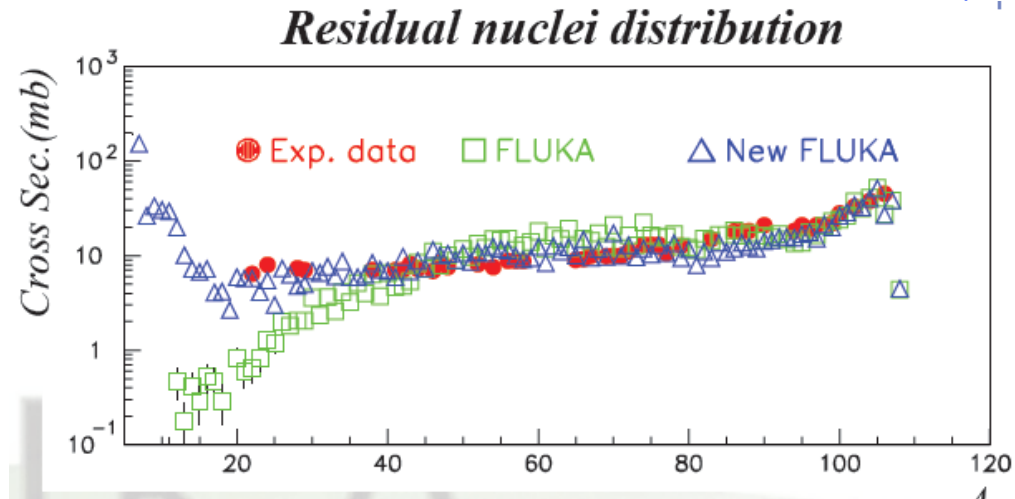

The fragmentation model has much improved the FLUKA predictions

Also for A-A interactions

Warning: fragmentation is OFF by default, because it is a cpu-eater. It is **NECESSARY** to activate it for activation studies:

PHYSICS 3.

EVAPORAT

If fragmentation is on, switch on Heavy ion transport and interactions (see later)

Summary of relevant input cards

PHYSICS 1000. 1000. 1000. 1000. 1000. 1000. PEATHRESH

to use the more refined PEANUT model for h-A reactions also above 5GeV

PHYSICS 3. EVAPORAT

to enable evaporation of heavy fragments

PHYSICS 1. COALESCE

to enable coalescence (at the cascade stage of the reaction, before pre-equilibrium)

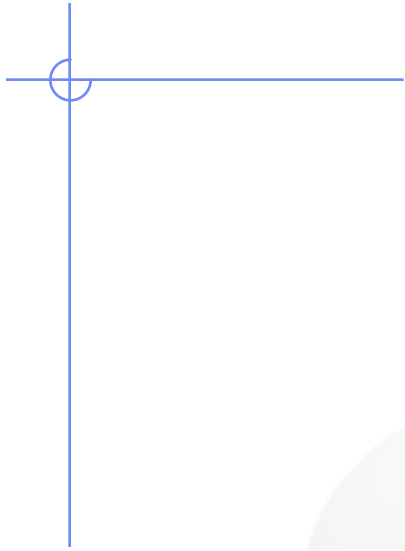

Glauber Cascade

Quantum mechanical method to compute all relevant hadron-nucleus cross sections from hadron-nucleon scattering: $S_{hN}(\vec{b}, s) = e^{i\chi_{hN}(\vec{b}, s)} = \eta_{hN}(\vec{b}, s) e^{2i\delta_{hN}(\vec{b}, s)}$

and nuclear ground state wave function Ψ_i

Total
$$\sigma_{hAT}(s) = 2 \int d^2\vec{b} \int d^3\vec{u} |\Psi_i(\vec{u})|^2 \left[1 - \prod_{j=1}^A \text{Re} S_{hN}(\vec{b} - \vec{r}_{j\perp}, s) \right]$$

Elastic
$$\sigma_{hAel}(s) = \int d^2\vec{b} \int d^3\vec{u} |\Psi_i(\vec{u})|^2 \left[1 - \prod_{j=1}^A S_{hN}(\vec{b} - \vec{r}_{j\perp}, s) \right]^2$$

Scattering
$$\sigma_{hA\Sigma f}(s) \equiv \sum_f \sigma_{hAfi}(s) = \int d^2\vec{b} \int d^3\vec{u} |\Psi_i(\vec{u})|^2 \left[1 - \prod_{j=1}^A S_{hN}(\vec{b} - \vec{r}_{j\perp}, s) \right]^2$$

Absorption (particle prod.)

Absorption probability over a given b and nucleon configuration

$$\sigma_{hAabs}(s) \equiv \sigma_{hAT}(s) - \sigma_{hA\Sigma f}(s)$$

$$= \int d^2\vec{b} \int d^3\vec{u} |\Psi_i(\vec{u})|^2 \left\{ 1 - \left[\prod_{j=1}^A 1 - \left[1 - |S_{hN}(\vec{b} - \vec{r}_{j\perp}, s)|^2 \right] \right] \right\}$$